

NOTES:  
 1. MATERIAL OF CONSTRUCTION IS 304 SS, BRUSHED #4.

UNLESS OTHERWISE SPECIFIED:  
 DIMENSIONS ARE IN INCHES  
 TOLERANCES:  
 FRACTIONAL  $\pm 1/32$   
 ANGULAR:  $\pm 2^\circ$   
 TWO PLACE DECIMAL  $\pm 0.010$   
 THREE PLACE DECIMAL  $\pm 0.005$   
 INTERPRET GEOMETRIC  
 TOLERANCING PER:  
 ASME Y14.5 -2009

NAME	DATE
DRAWN	
CHECKED	

TITLE:  
**INSTALLATION**

WEIGHT: 8.420	SIZE <b>A</b> PART NO. 88HOU-VIKI-02-304	REV <b>C</b>
	NO SCALE	SHEET 1 OF 6

ITEM NO.	PART NUMBER	DESCRIPTION	QTY.
1	88HOU-VIKI-02-304 ENCLOSURE	ENCLOSURE WELDMENT	1
2	88HOU-VIKI-02-304 DOOR	DOOR WELDMENT	1
3	88HOU-VIKI-02-304 HOOD	HOOD	1
4	HINGE	PIANO HINGE	1
5	CAM LOCK	STRAIGHT CAM	1
6	GASKET SIDE	3/8" X .150 WEATHERSTRIPPING	2
7	GASKET TOP	3/8" X .150 WEATHERSTRIPPING	1
8	--	6-32 PAN HEAD SCREW	4
9	--	6-32 EXTERNAL TOOTH LOCK NUT	4
10	--	8-32 HEX FLAT HEAD SCREW	4

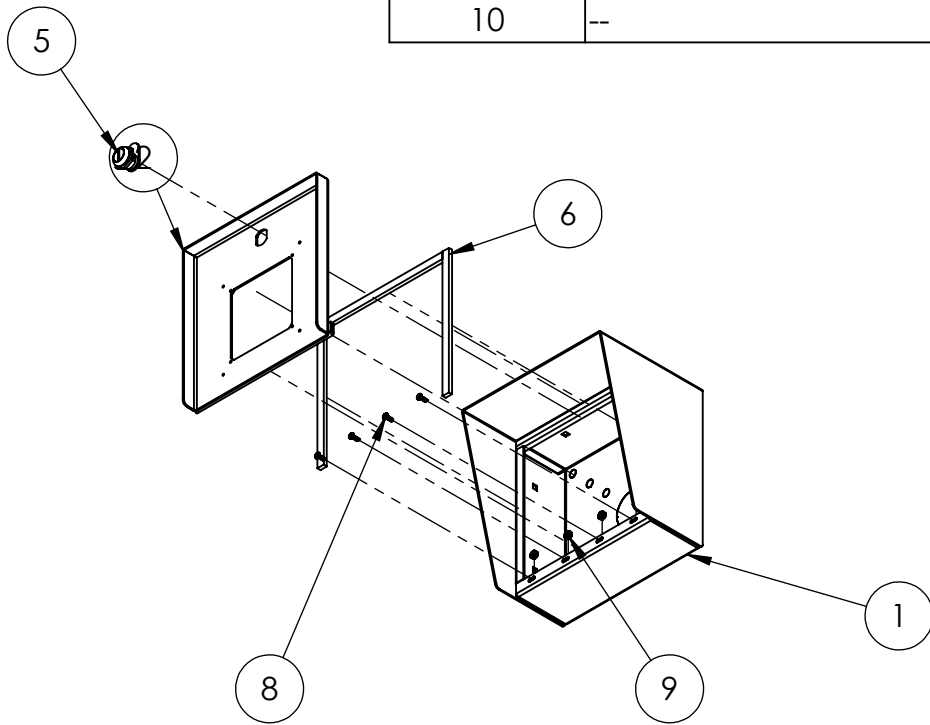

NOTES:

1. SEE STANDARD PREPARATION AND COATING INSTRUCTIONS FOR COATING PROCEDURE AND COLOR.
2. SEE STANDARD PACKAGING INSTRUCTIONS FOR PACKAGING PROCEDURE.

UNLESS OTHERWISE SPECIFIED:  
 DIMENSIONS ARE IN INCHES  
 TOLERANCES:  
 FRACTIONAL  $\pm 1/32$   
 ANGULAR:  $\pm 2^\circ$   
 TWO PLACE DECIMAL  $\pm 0.010$   
 THREE PLACE DECIMAL  $\pm 0.005$   
 INTERPRET GEOMETRIC  
 TOLERANCING PER:  
 ASME Y14.5 -2009

	NAME	DATE
DRAWN		
CHECKED		

TITLE: <b>ASSEMBLY</b>		SIZE <b>A</b>	PART NO. 88HOU-VIKI-02-304	REV <b>C</b>
WEIGHT: 8.420		NO SCALE		SHEET 2 OF 6