

NOTES:
 1. MATERIAL OF CONSTRUCTION IS 304 SS, BRUSHED #4.

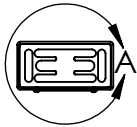

UNLESS OTHERWISE SPECIFIED: DIMENSIONS ARE IN INCHES TOLERANCES: FRACTIONAL $\pm 1/32$ ANGULAR: $\pm 2^\circ$ TWO PLACE DECIMAL ± 0.010 THREE PLACE DECIMAL ± 0.005	NAME	DATE
	DRAWN	
INTERPRET GEOMETRIC TOLERANCING PER: ASME Y14.5 -2009	CHECKED	
	PROPRIETARY AND CONFIDENTIAL	
THE INFORMATION CONTAINED IN THIS DRAWING IS THE SOLE PROPERTY OF PEDESTALPRO LLC. ANY REPRODUCTION IN PART OR AS A WHOLE WITHOUT THE WRITTEN PERMISSION OF PEDESTALPRO LLC IS PROHIBITED.		

TITLE: INSTALLATION		
Monday, November 30, 2020 3:50:00 PM	SIZE A	PART NO. 84TOW-2NIP-03-304
WEIGHT: 69.986	NO SCALE	REV A
		SHEET 1 OF 9

ITEM NO.	PART NUMBER	DESCRIPTION	QTY.
1	84TOW-2NIP-03-304	8X4 WELDMENT	1
2	PLTBAS-84-84	STANDARD BASE PLATE	1
3	PLTCAP-84-84-30	84-30 STANDARD CAP PLATE	1
4	PLTACC-510	STANDARD ACCESS COVER	1
5	BRA-IP2N-FM STYLE	FLUSH MOUNT BRACKET	1
6	--	8-32 X 1/2" PAN HEAD SCREW	32

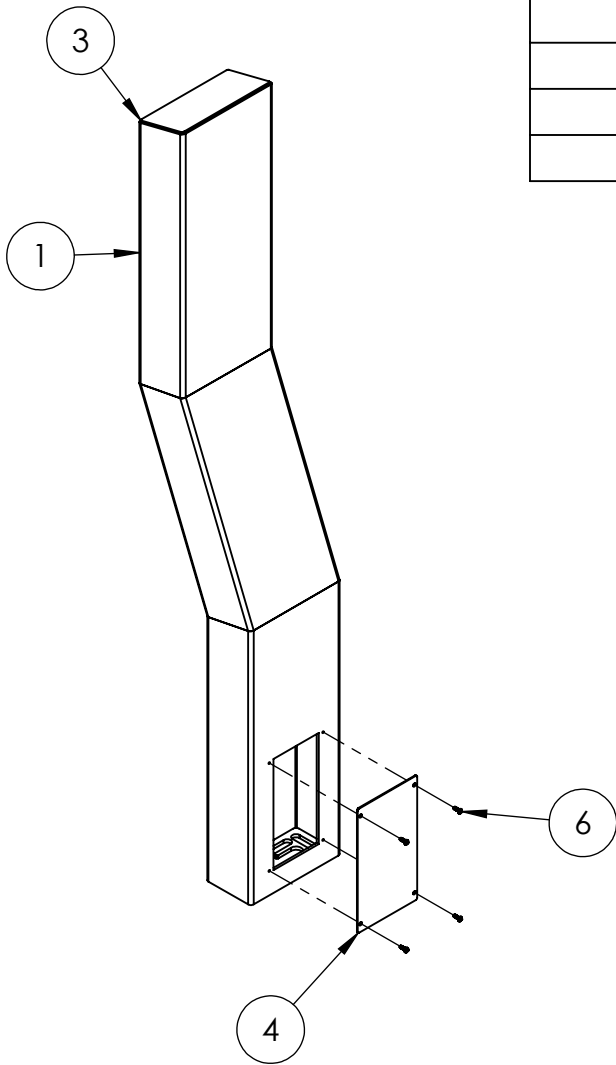

NOTES:

1. SEE STANDARD PREPARATION AND COATING INSTRUCTIONS FOR COATING PROCEDURE AND COLOR.
2. SEE STANDARD PACKAGING INSTRUCTIONS FOR PACKAGING PROCEDURE.

UNLESS OTHERWISE SPECIFIED: DIMENSIONS ARE IN INCHES TOLERANCES: FRACTIONAL $\pm 1/32$ ANGULAR: $\pm 2^\circ$ TWO PLACE DECIMAL ± 0.010 THREE PLACE DECIMAL ± 0.005 INTERPRET GEOMETRIC TOLERANCING PER: ASME Y14.5 -2009	NAME	DATE	TITLE: ASSEMBLY		SIZE	PART NO.	REV
	DRAWN			Monday, November 30, 2020 3:50:00 PM	A	84TOW-2NIP-03-304	A
	CHECKED		WEIGHT: 69.986		NO SCALE		SHEET 2 OF 9
PROPRIETARY AND CONFIDENTIAL THE INFORMATION CONTAINED IN THIS DRAWING IS THE SOLE PROPERTY OF PEDESTALPRO LLC. ANY REPRODUCTION IN PART OR AS A WHOLE WITHOUT THE WRITTEN PERMISSION OF PEDESTALPRO LLC IS PROHIBITED.							