

2N ACCESS UNIT M
SURFACE MOUNT

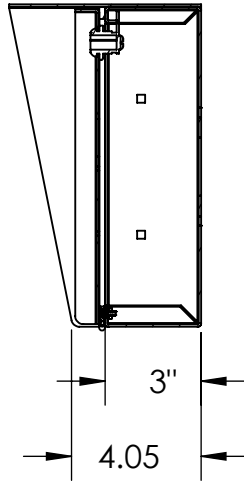

SECTION A-A

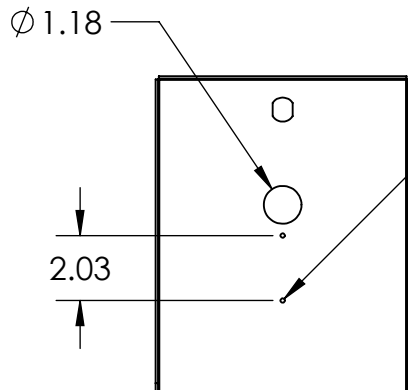
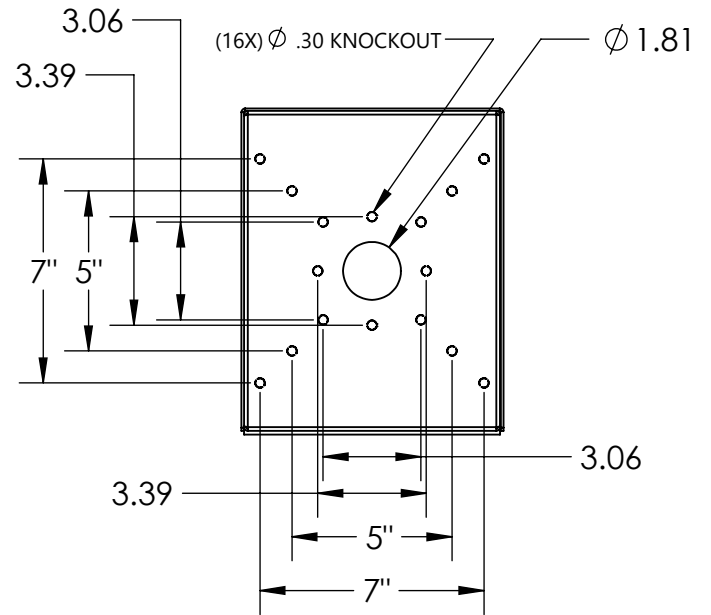

(2X) DRILL #29
TAP 8-32

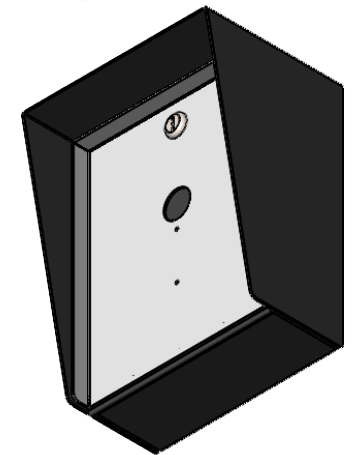

NOTES:

1. MATERIAL OF CONSTRUCTION IS MILD STEEL.
2. 2-4 MILS BLACK WRINKLE POWDER COAT. (8017-91612)

UNLESS OTHERWISE SPECIFIED:
 DIMENSIONS ARE IN INCHES
 TOLERANCES:
 FRACTIONAL $\pm 1/32$
 ANGULAR: $\pm 2^\circ$
 TWO PLACE DECIMAL ± 0.010
 THREE PLACE DECIMAL ± 0.005
 INTERPRET GEOMETRIC
 TOLERANCING PER:
 ASME Y14.5 -2009

NAME	DATE
DRAWN	
CHECKED	

TITLE:
INSTALLATION

SIZE A	PART NO. 810HOU-2NIP-010-CRS	REV A
WEIGHT:	NO SCALE	SHEET 1 OF 6

ITEM NO.	PART NUMBER	DESCRIPTION	QTY.
1	810HOU-2NIP-010-CRS ENCLOSURE	ENCLOSURE WELDMENT	1
2	810HOU-2NIP-010-CRS DOOR	DOOR	1
3	810HOU-2NIP-010-CRS HOOD	HOOD	1
4	CAM LOCK	Straight Cam	1
5	HINGE	PIANO HINGE	1
6	GASKET SIDE	3/8 X .150 WEATHERSTRIPPING	2
7	GASKET TOP	3/8 X .150 WEATHERSTRIPPING	1
8	--	6-32 EXTERNAL TOOTH LOCK NUT	3
9	--	6-32 X 3/8 SS BUTTON HEAD SCREW	3

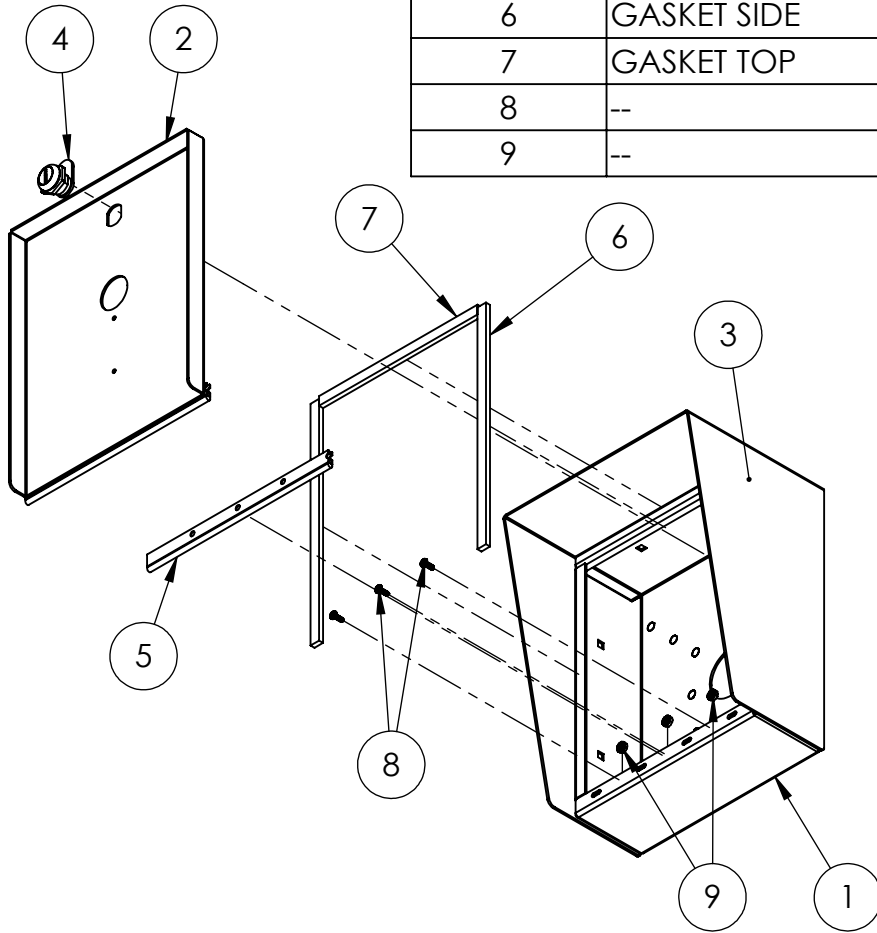

NOTES:

1. SEE STANDARD PREPARATION AND COATING INSTRUCTIONS FOR COATING PROCEDURE AND COLOR.
2. SEE STANDARD PACKAGING INSTRUCTIONS FOR PACKAGING PROCEDURE.

UNLESS OTHERWISE SPECIFIED:

DIMENSIONS ARE IN INCHES
TOLERANCES:
FRACTIONAL $\pm 1/32$
ANGULAR: $\pm 2^\circ$
TWO PLACE DECIMAL ± 0.010
THREE PLACE DECIMAL ± 0.005

INTERPRET GEOMETRIC
TOLERANCING PER:
ASME Y14.5 -2009

NAME DATE

DRAWN
CHECKED

TITLE:

ASSEMBLY

SIZE
A

PART NO.
810HOU-2NIP-010-CRS

REV
A

WEIGHT:

NO SCALE

SHEET 2 OF 6