

- NOTES:
1. MATERIAL OF CONSTRUCTION IS MILD STEEL.
 2. 2-4 MILS BLACK WRINKLE POWDER COAT.

UNLESS OTHERWISE SPECIFIED: DIMENSIONS ARE IN INCHES TOLERANCES: FRACTIONAL $\pm 1/32$ ANGULAR: $\pm 2^\circ$ TWO PLACE DECIMAL ± 0.010 THREE PLACE DECIMAL ± 0.005 INTERPRET GEOMETRIC TOLERANCING PER: ASME Y14.5 -2009	NAME	DATE
	DRAWN	
	CHECKED	
PROPRIETARY AND CONFIDENTIAL		
THE INFORMATION CONTAINED IN THIS DRAWING IS THE SOLE PROPERTY OF PEDESTALPRO LLC. ANY REPRODUCTION IN PART OR AS A WHOLE WITHOUT THE WRITTEN PERMISSION OF PEDESTALPRO LLC IS PROHIBITED.		

TITLE: INSTALLATION		
Wednesday, August 18, 2021 2:34:11 PM	SIZE A	PART NO. 66TOW-PRO-003-CRS
WEIGHT: 251.460	NO SCALE	REV A
		SHEET 1 OF 9

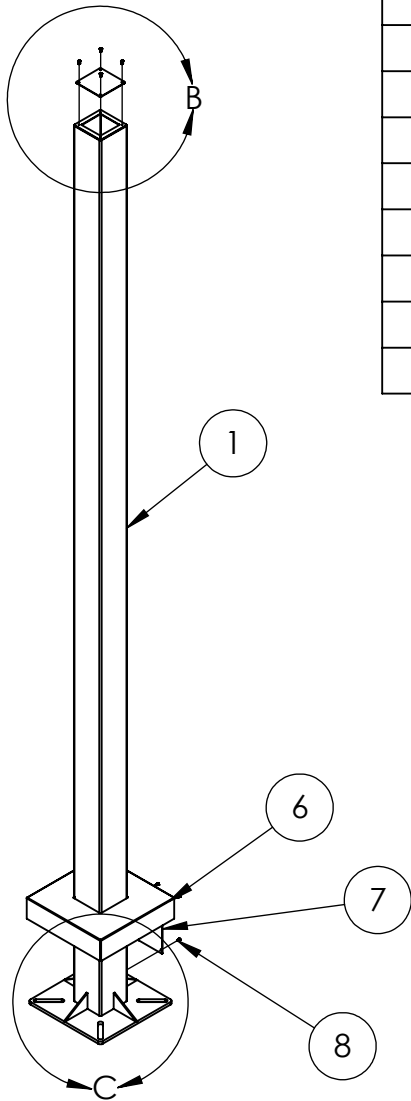

ITEM NO.	PART NUMBER	DESCRIPTION	QTY.
1	66TOW-PRO-003-CRS	6X6 MILD STEEL TUBE	1
2	66TOW-PRO-003-CRS TOP PLATE	TOP PLATE	1
3	66TOW-PRO-003-CRS TOP ACCESS	TOP ACCESS	1
4	PLTBAS-16-6 PLATE	16" BASE PLATE	1
5	PLTBAS-16 GUSSET	GUSSET	4
6	PLTCOV-16-6	16" COVER PLATE	1
7	PLTACC-510	STANDARD ACCESS COVER	1
8	--	8-32 X 1/2" PAN HEAD SCREW	8

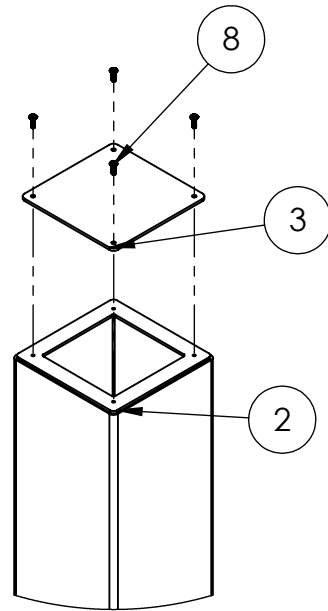

DETAIL B

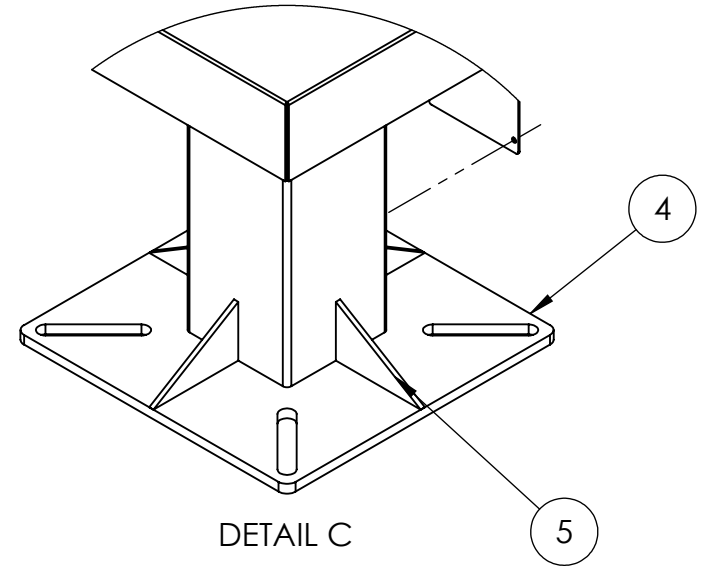

DETAIL C

NOTES:

1. SEE STANDARD PREPARATION AND COATING INSTRUCTIONS FOR COATING PROCEDURE AND COLOR.
2. SEE STANDARD PACKAGING INSTRUCTIONS FOR PACKAGING PROCEDURE.

UNLESS OTHERWISE SPECIFIED:

DIMENSIONS ARE IN INCHES
 TOLERANCES:
 FRACTIONAL $\pm 1/32$
 ANGULAR: $\pm 2^\circ$
 TWO PLACE DECIMAL ± 0.010
 THREE PLACE DECIMAL ± 0.005

INTERPRET GEOMETRIC
 TOLERANCING PER:
 ASME Y14.5 -2009

NAME	DATE
DRAWN	
CHECKED	

PROPRIETARY AND CONFIDENTIAL
 THE INFORMATION CONTAINED IN THIS
 DRAWING IS THE SOLE PROPERTY OF
 PEDESTALPRO LLC. ANY REPRODUCTION
 IN PART OR AS A WHOLE WITHOUT THE
 WRITTEN PERMISSION OF PEDESTALPRO LLC
 IS PROHIBITED.

TITLE:
ASSEMBLY

Tuesday, May 25, 2021
 2:39:26 PM

WEIGHT: 251.460

SIZE **A** PART NO.
 66TOW-PRO-003-CRS

REV
0

NO SCALE

SHEET 2 OF 9