

NOTES:

1. 1/2 ϕ MOUNTING HARDWARE IS RECOMMENDED, STUD-ANCHOR-500 OR L-BOLT-500.
2. COATED IN 2-4 MILS ANODIZED ALUMINUM COLOR POWDER COATING.
3. *ANODIZED COATING NOT AVAILABLE.

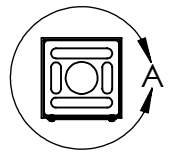

UNLESS OTHERWISE SPECIFIED: DIMENSIONS ARE IN INCHES TOLERANCES: FRACTIONAL $\pm 1/32$ ANGULAR: $\pm 2^\circ$ TWO PLACE DECIMAL ± 0.010 THREE PLACE DECIMAL ± 0.005 INTERPRET GEOMETRIC TOLERANCING PER: ASME Y14.5 -2009	NAME DATE	TITLE: INSTALLATION	
	DRAWN CHECKED	Friday, May 29, 2020 9:11:32 AM	
	PROPRIETARY AND CONFIDENTIAL THE INFORMATION CONTAINED IN THIS DRAWING IS THE SOLE PROPERTY OF PEDESTALPRO LLC. ANY REPRODUCTION IN PART OR AS A WHOLE WITHOUT THE WRITTEN PERMISSION OF PEDESTALPRO LLC IS PROHIBITED.		SIZE A
	WEIGHT: 12.262	NO SCALE	SHEET 1 OF 7

ITEM NO.	PART NUMBER	DESCRIPTION	QTY.
1	55TOW-PRO-001-ALU TUBE	6061 ALUM BODY	1
2	PLACAP-5-5-ALU	5 X 5 ALUM CAP PLATE	1
3	PLTACC-410	5" STND ACCESS PANEL	1
4	PLTBAS-5-5-ALU	5" STANDARD BASE PLATE	1
5	--	8-32 PAN HEAD SCREW	4

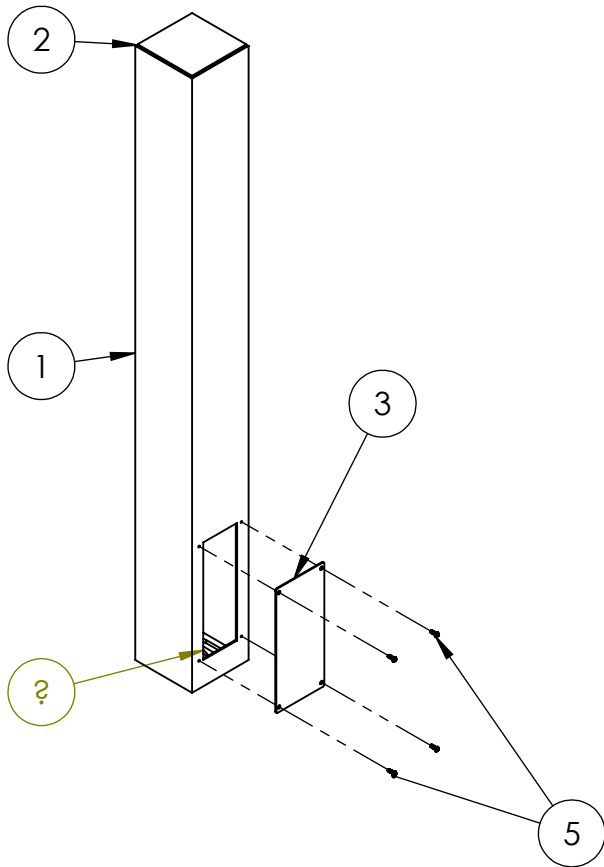

NOTES:

1. SEE STANDARD PREPARATION AND COATING INSTRUCTIONS FOR COATING PROCEDURE AND COLOR.
2. SEE STANDARD PACKAGING INSTRUCTIONS FOR PACKAGING PROCEDURE.

UNLESS OTHERWISE SPECIFIED:

DIMENSIONS ARE IN INCHES
 TOLERANCES:
 FRACTIONAL $\pm 1/32$
 ANGULAR: $\pm 2^\circ$
 TWO PLACE DECIMAL ± 0.010
 THREE PLACE DECIMAL ± 0.005

INTERPRET GEOMETRIC
 TOLERANCING PER:
 ASME Y14.5 -2009

NAME	DATE
DRAWN	
CHECKED	

PROPRIETARY AND CONFIDENTIAL
 THE INFORMATION CONTAINED IN THIS
 DRAWING IS THE SOLE PROPERTY OF
 PEDESTALPRO LLC. ANY REPRODUCTION
 IN PART OR AS A WHOLE WITHOUT THE
 WRITTEN PERMISSION OF PEDESTALPRO LLC
 IS PROHIBITED.

TITLE:
ASSEMBLY

Friday, May 29, 2020
 9:11:32 AM

WEIGHT: 12.262

SIZE A	PART NO. 55TOW-PRO-001-ALU	REV 0
------------------	-------------------------------	-----------------

NO SCALE

SHEET 2 OF 7