

NOTES:

1. 1/2  $\phi$  MOUNTING HARDWARE IS RECOMMENDED, STUD-ANCHOR-500 OR L-BOLT-500.
2. COATED IN 2-4 MILS ANODIZED ALUMINUM COLOR POWDER COATING.
3. \*ANODIZED COATING NOT AVAILABLE.

UNLESS OTHERWISE SPECIFIED:  DIMENSIONS ARE IN INCHES TOLERANCES: FRACTIONAL $\pm 1/32$ ANGULAR: $\pm 2^\circ$ TWO PLACE DECIMAL $\pm 0.010$ THREE PLACE DECIMAL $\pm 0.005$  INTERPRET GEOMETRIC TOLERANCING PER: ASME Y14.5 -2009	DRAWN	NAME	DATE	TITLE:	SIZE	PART NO.	REV
	CHECKED			<b>INSTALLATION</b>	<b>A</b>	44TOW-PRO-001-ALU	<b>0</b>
	<b>PROPRIETARY AND CONFIDENTIAL</b> THE INFORMATION CONTAINED IN THIS DRAWING IS THE SOLE PROPERTY OF PEDESTALPRO LLC. ANY REPRODUCTION IN PART OR AS A WHOLE WITHOUT THE WRITTEN PERMISSION OF PEDESTALPRO LLC IS PROHIBITED.			Friday, May 29, 2020 9:11:32 AM	WEIGHT: 9.643	NO SCALE	SHEET 1 OF 7

ITEM NO.	PART NUMBER	DESCRIPTION	QTY.
1	44TOW-PRO-001-ALU TUBE	6061 ALUM BODY	1
2	PLACAP-4-4-ALU	4 X 4 ALUM CAP PLATE	1
3	PLTACC-310	4" STND 304 SS ACCESS PANEL	1
4	PLTBAS-4-4-ALU	4" STANDARD ALUM BASE PLATE	1
5	--	8-32 PAN HEAD SCREW	4

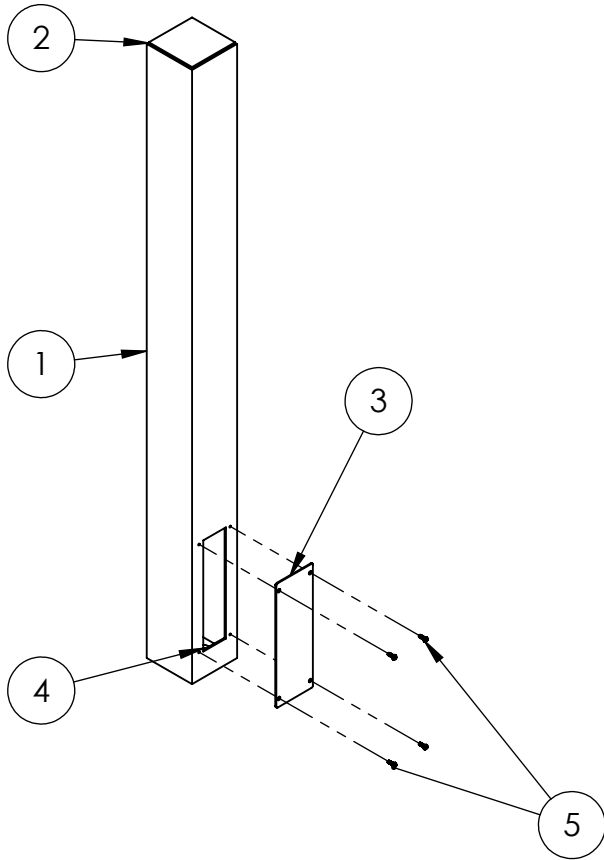

NOTES:

1. SEE STANDARD PREPARATION AND COATING INSTRUCTIONS FOR COATING PROCEDURE AND COLOR.
2. SEE STANDARD PACKAGING INSTRUCTIONS FOR PACKAGING PROCEDURE.

UNLESS OTHERWISE SPECIFIED:

DIMENSIONS ARE IN INCHES  
TOLERANCES:  
FRACTIONAL  $\pm 1/32$   
ANGULAR:  $\pm 2^\circ$   
TWO PLACE DECIMAL  $\pm 0.010$   
THREE PLACE DECIMAL  $\pm 0.005$

INTERPRET GEOMETRIC  
TOLERANCING PER:  
ASME Y14.5 -2009

NAME	DATE
DRAWN	
CHECKED	

**PROPRIETARY AND CONFIDENTIAL**  
THE INFORMATION CONTAINED IN THIS  
DRAWING IS THE SOLE PROPERTY OF  
PEDESTALPRO LLC. ANY REPRODUCTION  
IN PART OR AS A WHOLE WITHOUT THE  
WRITTEN PERMISSION OF PEDESTALPRO LLC  
IS PROHIBITED.

TITLE:  
**ASSEMBLY**

Friday, May 29, 2020  
9:11:32 AM

WEIGHT: 9.643

SIZE  
**A**

PART NO.  
44TOW-PRO-001-ALU

REV  
**0**

NO SCALE

SHEET 2 OF 7