

NOTES:

1. MATERIAL OF CONSTRUCTION IS MILD STEEL COATED IN 2-4 MILS BLACK WRINKLE POWDER COATING.

UNLESS OTHERWISE SPECIFIED:

DIMENSIONS ARE IN INCHES
 TOLERANCES:
 FRACTIONAL $\pm 1/32$
 ANGULAR: $\pm 2^\circ$
 TWO PLACE DECIMAL ± 0.010
 THREE PLACE DECIMAL ± 0.005

INTERPRET GEOMETRIC
 TOLERANCING PER:
 ASME Y14.5 -2009

NAME DATE

DRAWN
 CHECKED

TITLE:

INSTALLATION

SIZE
A

PART NO.
 410HOO-OPEN-02-CRS

REV
0

WEIGHT: 2.613

NO SCALE

SHEET 1 OF 6

ITEM NO.	PART NUMBER	DESCRIPTION	QTY.
1	410HOO-OPEN-02-CRS	HOOD ASSEMBLY	1
2	410HOO-OPEN-02-CRS MID PLATE	MOUNTING PLATE	1

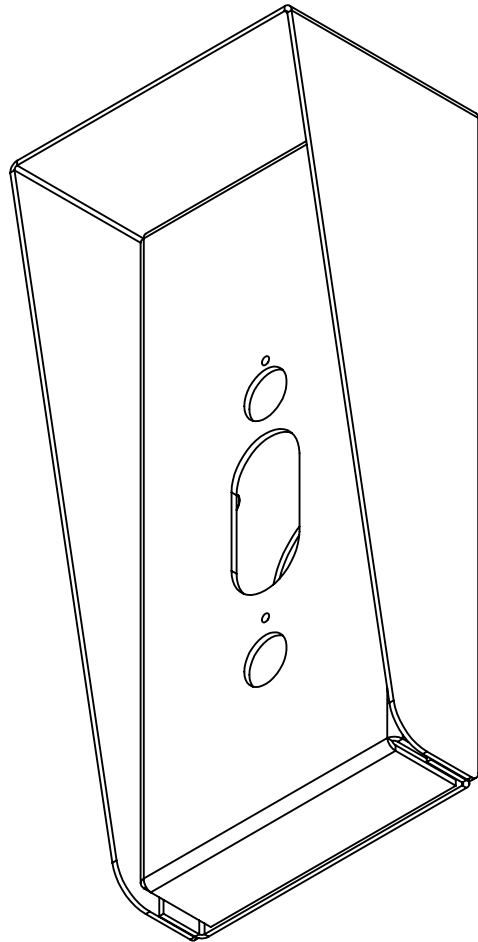

NOTES:

1. SEE STANDARD PREPARATION AND COATING INSTRUCTIONS FOR COATING PROCEDURE AND COLOR.
2. SEE STANDARD PACKAGING INSTRUCTIONS FOR PACKAGING PROCEDURE.

UNLESS OTHERWISE SPECIFIED:

DIMENSIONS ARE IN INCHES
TOLERANCES:
FRACTIONAL $\pm 1/32$
ANGULAR: $\pm 2^\circ$
TWO PLACE DECIMAL ± 0.010
THREE PLACE DECIMAL ± 0.005

INTERPRET GEOMETRIC
TOLERANCING PER:
ASME Y14.5 -2009

	NAME	DATE
DRAWN		
CHECKED		

TITLE:
ASSEMBLY

SIZE A	PART NO. 410HOO-OPEN-02-CRS	REV 0
WEIGHT: 2.613	NO SCALE	SHEET 2 OF 6