

NOTES:  
 1. MATERIAL OF CONSTRUCTION IS MILD STEEL COATED IN 2-4 MILS FLAT BLACK WITH ZINC ENRICHED PRIMER.

UNLESS OTHERWISE SPECIFIED:  DIMENSIONS ARE IN INCHES TOLERANCES: FRACTIONAL $\pm 1/32$ ANGULAR: $\pm 2^\circ$ TWO PLACE DECIMAL $\pm 0.010$ THREE PLACE DECIMAL $\pm 0.005$  INTERPRET GEOMETRIC TOLERANCING PER: ASME Y14.5 -2009	NAME	DATE	TITLE:	SIZE	PART NO.	REV
	DRAWN			<b>A</b>	33PE1-INVU-01-CRS	0
	CHECKED			WEIGHT: 36.765	NO SCALE	SHEET 1 OF 4

ITEM NO.	PART NUMBER	DESCRIPTION	QTY.
1	33PE1-INVU-01-CRS	3 X 3 WELDMENT	1
2	PLTBAS-8-3	8" STANDARD BASE PLATE	1
3	PLTCOV-8-3	STANDARD COVER PLATE	1
4	33PE1-INVU-01-CRS FACE	CUSTOM INVICTUS FACE PLATE	1
5	--	1/4-20 X .5 ZINC PL CARRIAGE BOLT	4
6	--	1/4-20 ZINC PL HEX NUT	4

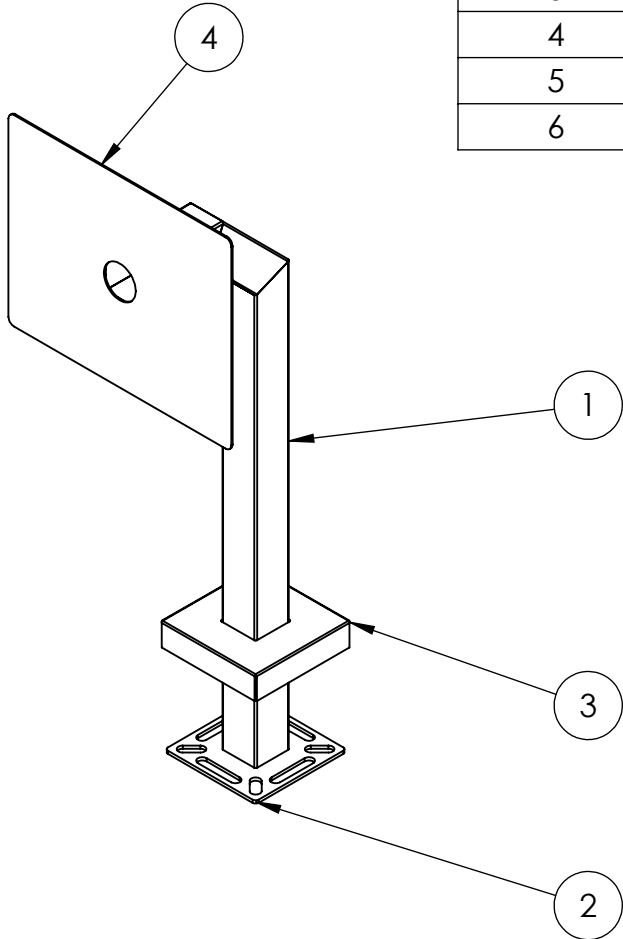

NOTES:

1. SEE STANDARD PREPARATION AND COATING INSTRUCTIONS FOR COATING PROCEDURE AND COLOR.
2. SEE STANDARD PACKAGING INSTRUCTIONS FOR PACKAGING PROCEDURE.

UNLESS OTHERWISE SPECIFIED:

DIMENSIONS ARE IN INCHES  
TOLERANCES:  
FRACTIONAL  $\pm 1/32$   
ANGULAR:  $\pm 2^\circ$   
TWO PLACE DECIMAL  $\pm 0.010$   
THREE PLACE DECIMAL  $\pm 0.005$

INTERPRET GEOMETRIC  
TOLERANCING PER:  
ASME Y14.5 -2009

NAME	DATE
DRAWN	
CHECKED	

TITLE:  
**ASSEMBLY**

WEIGHT: 36.765	SIZE <b>A</b>	PART NO. 33PE1-INVU-01-CRS	REV <b>0</b>
	NO SCALE	SHEET 2 OF 4	