

NOTES:
 1. MATERIAL OF CONSTRUCTION IS BRUSHED #4 304 SS.

UNLESS OTHERWISE SPECIFIED: DIMENSIONS ARE IN INCHES TOLERANCES: FRACTIONAL $\pm 1/32$ ANGULAR: $\pm 2^\circ$ TWO PLACE DECIMAL ± 0.010 THREE PLACE DECIMAL ± 0.005 INTERPRET GEOMETRIC TOLERANCING PER: ASME Y14.5 -2009		NAME	DATE
	DRAWN		
	CHECKED		
	PROPRIETARY AND CONFIDENTIAL		
	THE INFORMATION CONTAINED IN THIS DRAWING IS THE SOLE PROPERTY OF PEDESTALPRO LLC. ANY REPRODUCTION IN PART OR AS A WHOLE WITHOUT THE WRITTEN PERMISSION OF PEDESTALPRO LLC IS PROHIBITED.		

TITLE: INSTALLATION			
Thursday, August 20, 2020 2:02:32 PM	SIZE A	PART NO. 1414PLA-MVI-001-304	REV 0
WEIGHT: 9.897	NO SCALE		SHEET 1 OF 4

ITEM NO.	PART NUMBER	DESCRIPTION	QTY.
1	MOUNTING PLATE	KEYCOM BOLT MOUNTING PLATE	1
2	BACK PLATE	304 SS BACKING PLATE	1

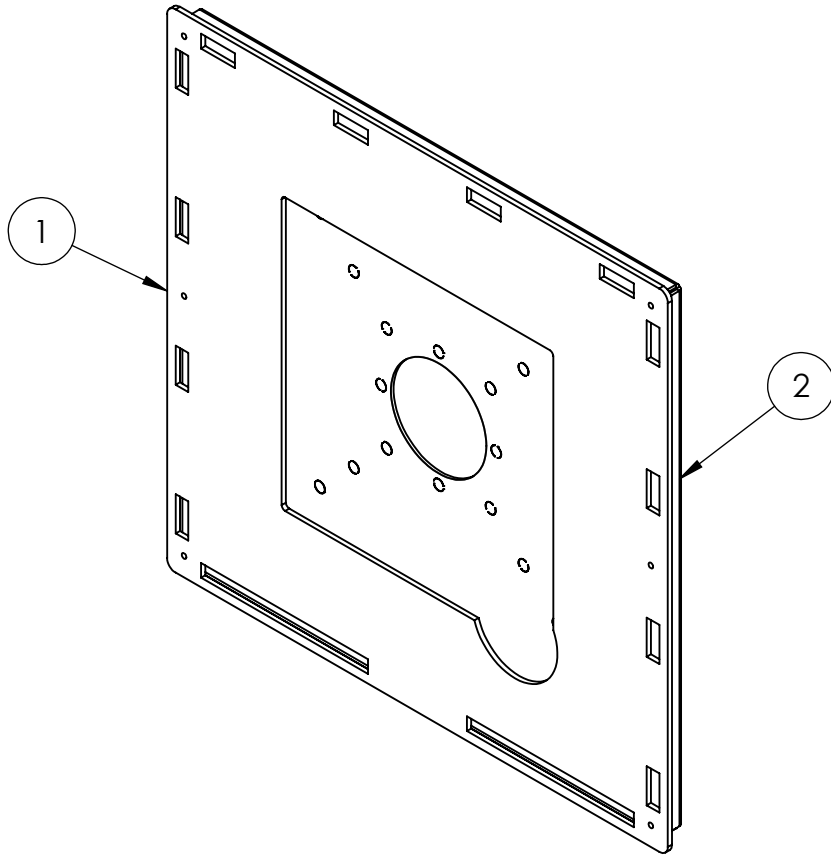

NOTES:

1. SEE STANDARD PREPARATION AND COATING INSTRUCTIONS FOR COATING PROCEDURE AND COLOR.
2. SEE STANDARD PACKAGING INSTRUCTIONS FOR PACKAGING PROCEDURE.

UNLESS OTHERWISE SPECIFIED:

DIMENSIONS ARE IN INCHES
TOLERANCES:
FRACTIONAL $\pm 1/32$
ANGULAR: $\pm 2^\circ$
TWO PLACE DECIMAL ± 0.010
THREE PLACE DECIMAL ± 0.005

INTERPRET GEOMETRIC
TOLERANCING PER:
ASME Y14.5 -2009

NAME	DATE
DRAWN	
CHECKED	

PROPRIETARY AND CONFIDENTIAL
THE INFORMATION CONTAINED IN THIS
DRAWING IS THE SOLE PROPERTY OF
PEDESTALPRO LLC. ANY REPRODUCTION
IN PART OR AS A WHOLE WITHOUT THE
WRITTEN PERMISSION OF PEDESTALPRO LLC
IS PROHIBITED.

TITLE:
ASSEMBLY

Thursday, August 20,
2020 2:02:32 PM

WEIGHT: 9.897

SIZE A	PART NO. 1414PLA-MVI-001-304
------------------	---------------------------------

REV 0

NO SCALE

SHEET 2 OF 4