

MOUNTS A COMELIT 3ONE6

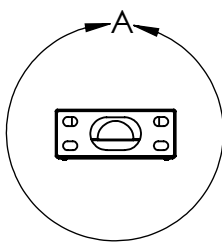
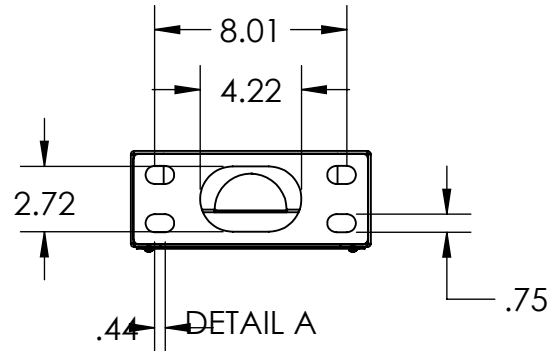
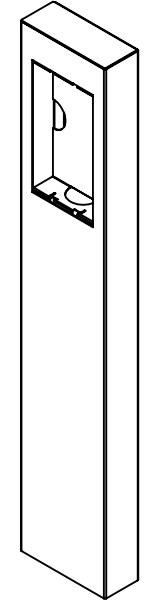
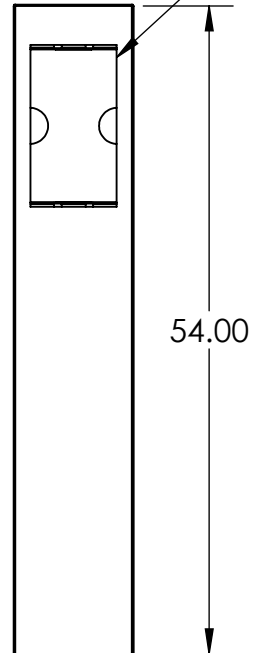

- NOTES:
1. MATERIAL OF CONSTRUCTION IS MILD STEEL.
 2. 2-4 MILS FLAT BLACK POWDER COAT.

UNLESS OTHERWISE SPECIFIED: DIMENSIONS ARE IN INCHES TOLERANCES: FRACTIONAL $\pm 1/32$ ANGULAR: $\pm 2^\circ$ TWO PLACE DECIMAL ± 0.010 THREE PLACE DECIMAL ± 0.005 INTERPRET GEOMETRIC TOLERANCING PER: ASME Y14.5 -2009	NAME DATE	TITLE: <h1>INSTALLATION</h1>	
	DRAWN CHECKED	Tuesday, March 12, 2024 3:12:46 PM	
	PROPRIETARY AND CONFIDENTIAL THE INFORMATION CONTAINED IN THIS DRAWING IS THE SOLE PROPERTY OF PEDESTALPRO LLC. ANY REPRODUCTION IN PART OR AS A WHOLE WITHOUT THE WRITTEN PERMISSION OF PEDESTALPRO LLC IS PROHIBITED.	SIZE A	PART NO. 104TOW-COM-001-CRS
WEIGHT: 46.044		NO SCALE	SHEET 1 OF 9

ITEM NO.	PART NUMBER	DESCRIPTION	QTY.
1	104TOW-COM-001-CRS MAIN BODY	MAIN BODY	1
2	104TOW-COM-001-CRS TOP	TOP	1
3	104TOW-COM-001-CRS BOTTOM CLOSURE	BOTTOM CLOSURE	1
4	104TOW-COM-001-CRS BASE PLATE	BASE PLATE	1
5	104TOW-COM-001-CRS ACCESS PANEL	ACCESS PANEL	1
6	BRA-COME-3ONE6	3ONE6 BRACKET	1
7	--	10-24 X 1/2" WELD STUD	4
8	--	8-32 X 1/2" PAN HEAD SCREW	10
9	--	10-24 SS NYLON LOCK NUT	4

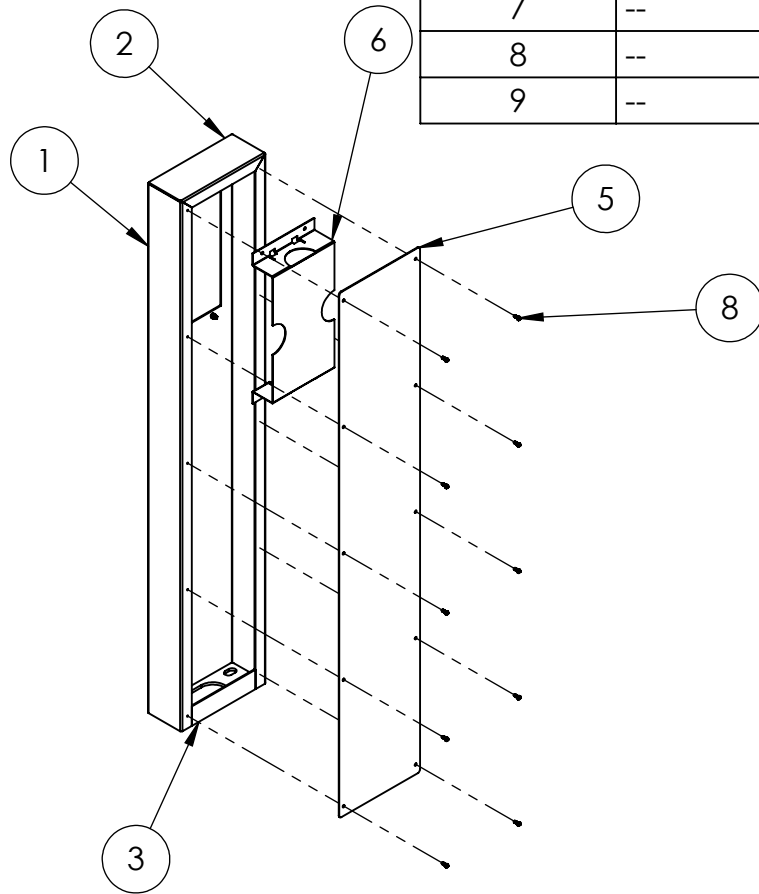

NOTES:

- SEE STANDARD PREPARATION AND COATING INSTRUCTIONS FOR COATING PROCEDURE AND COLOR.
- SEE STANDARD PACKAGING INSTRUCTIONS FOR PACKAGING PROCEDURE.

UNLESS OTHERWISE SPECIFIED:

DIMENSIONS ARE IN INCHES
TOLERANCES:
FRACTIONAL $\pm 1/32$
ANGULAR: $\pm 2^\circ$
TWO PLACE DECIMAL ± 0.010
THREE PLACE DECIMAL ± 0.005

INTERPRET GEOMETRIC
TOLERANCING PER:
ASME Y14.5 -2009

NAME	DATE
DRAWN	
CHECKED	

PROPRIETARY AND CONFIDENTIAL
THE INFORMATION CONTAINED IN THIS DRAWING IS THE SOLE PROPERTY OF PEDESTALPRO LLC. ANY REPRODUCTION IN PART OR AS A WHOLE WITHOUT THE WRITTEN PERMISSION OF PEDESTALPRO LLC IS PROHIBITED.

TITLE: ASSEMBLY		SIZE A	PART NO. 104TOW-COM-001-CRS	REV A
Tuesday, March 12, 2024 3:12:46 PM		NO SCALE		SHEET 2 OF 9
WEIGHT: 46.044				