

AVAILABLE CUTOUT AREA

- NOTES:
 1. MATERIAL OF CONSTRUCTION IS 304 SS, BRUSHED #4.

www.GooseneckStands.com (888) 378 - 1045 Sales@GooseneckStands.com	UNLESS OTHERWISE SPECIFIED: ★	NAME	DATE	TITLE:			
	DIMENSIONS ARE IN INCHES TOLERANCES: FRACTIONAL ± 1/32 ANGULAR: ± 2° TWO PLACE DECIMAL ± 0.010 THREE PLACE DECIMAL ± 0.005	DRAWN			INSTALLATION		
INTERPRET GEOMETRIC TOLERANCING PER: ASME Y14.5 -2009	CHECKED			Tuesday, January 14, 2025 10:18:14 AM		SIZE A	PART NO. 812HOU-AKUV-01-304 (X912S) NO SCALE
PROPRIETARY AND CONFIDENTIAL THE INFORMATION CONTAINED IN THIS DRAWING IS THE SOLE PROPERTY OF PEDESTALPRO LLC. ANY REPRODUCTION IN PART OR AS A WHOLE WITHOUT THE WRITTEN PERMISSION OF PEDESTALPRO LLC IS PROHIBITED.				WEIGHT: 11.437	SHEET 1 OF 6		

ITEM NO.	PART NUMBER	DESCRIPTION	QTY.
1	812HOU-AKUV-01-304 ENCLOSURE (X912S)	ENCLOSURE WELDMENT	1
2	812HOU-AKUV-01-304 HOOD (X912S)	HOOD	1
3	812HOU-AKUV-01-304 DOOR (X912S)	DOOR WELDMENT	1
4	CAM LOCK	STRAIGHT CAM	1
5	HINGE	PIANO HINGE	1
6	GASKET SIDE	3/8" X .150 WEATHERSTRIPPING	2
7	GASKET TOP	3/8" X .150 WEATHERSTRIPPING	1
8	--	6-32 PAN HEAD SCREW	4
9	--	6-32 EXTERNAL TOOTH LOCK NUT	4

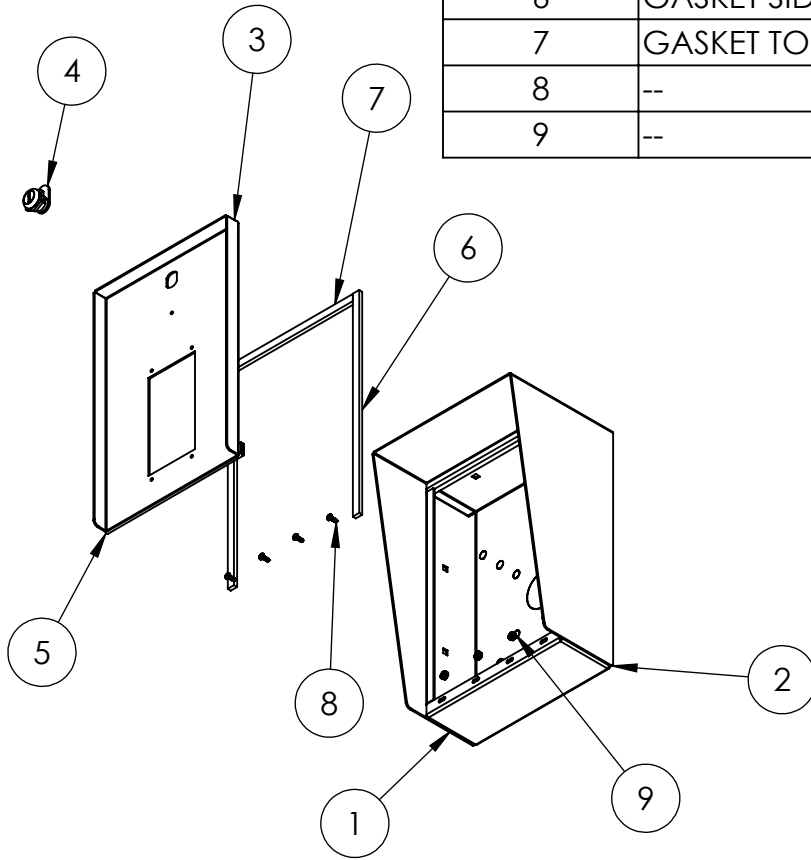

NOTES:

1. SEE STANDARD PREPARATION AND COATING INSTRUCTIONS FOR COATING PROCEDURE AND COLOR.
2. SEE STANDARD PACKAGING INSTRUCTIONS FOR PACKAGING PROCEDURE.

www.GooseneckStands.com (888) 378 - 1045 Sales@GooseneckStands.com	UNLESS OTHERWISE SPECIFIED:	NAME	DATE	TITLE:			
	DIMENSIONS ARE IN INCHES TOLERANCES: FRACTIONAL ± 1/32 ANGULAR: ± 2° TWO PLACE DECIMAL ± 0.010 THREE PLACE DECIMAL ± 0.005	DRAWN			ASSEMBLY	SIZE	PART NO.
INTERPRET GEOMETRIC TOLERANCING PER: ASME Y14.5 -2009	CHECKED			Tuesday, January 14, 2025 10:18:14 AM		A	812HOU-AKUV-01-304 (X912S) NO SCALE
PROPRIETARY AND CONFIDENTIAL THE INFORMATION CONTAINED IN THIS DRAWING IS THE SOLE PROPERTY OF PEDESTALPRO LLC. ANY REPRODUCTION IN PART OR AS A WHOLE WITHOUT THE WRITTEN PERMISSION OF PEDESTALPRO LLC IS PROHIBITED.				WEIGHT: 11.437			SHEET 2 OF 6