

NOTES:  
 1. MATERIAL OF CONSTRUCTION IS 304 SS, BRUSHED #4.

<a href="http://www.GooseneckStands.com">www.GooseneckStands.com</a> (888) 378 - 1045 <a href="mailto:Sales@GooseneckStands.com">Sales@GooseneckStands.com</a>	UNLESS OTHERWISE SPECIFIED: ★	NAME	DATE	TITLE:		
	DIMENSIONS ARE IN INCHES TOLERANCES: FRACTIONAL $\pm 1/32$ ANGULAR: $\pm 2^\circ$ TWO PLACE DECIMAL $\pm 0.010$ THREE PLACE DECIMAL $\pm 0.005$	DRAWN			<b>INSTALLATION</b>	SIZE
	CHECKED			Monday, December 9, 2024 12:44:20 PM		<b>A</b>
	<b>PROPRIETARY AND CONFIDENTIAL</b> THE INFORMATION CONTAINED IN THIS DRAWING IS THE SOLE PROPERTY OF PEDESTALPRO LLC. ANY REPRODUCTION IN PART OR AS A WHOLE WITHOUT THE WRITTEN PERMISSION OF PEDESTALPRO LLC IS PROHIBITED.			WEIGHT: 10.225	NO SCALE	REV <b>A</b>
					SHEET 1 OF 6	

ITEM NO.	PART NUMBER	DESCRIPTION	QTY.
1	810HOU-LIFT-01-304 (KPW5) ENCLOSURE	ENCLOSURE WELDMENT	1
2	810HOU-LIFT-01-304 (KPW5) HOOD	HOOD	1
3	810HOU-LIFT-01-304 (KPW5) DOOR	DOOR WELDMENT	1
4	HINGE	PIANO HINGE	1
5	CAM LOCK	STRAIGHT CAM	1
6	GASKET SIDE	3/8" X .150 WEATHERSTRIPPING	2
7	GASKET TOP	3/8" X .150 WEATHERSTRIPPING	1
8	--	6-32 PAN HEAD SCREW	4
9	--	6-32 EXTERNAL TOOTH LOCK NUT	4

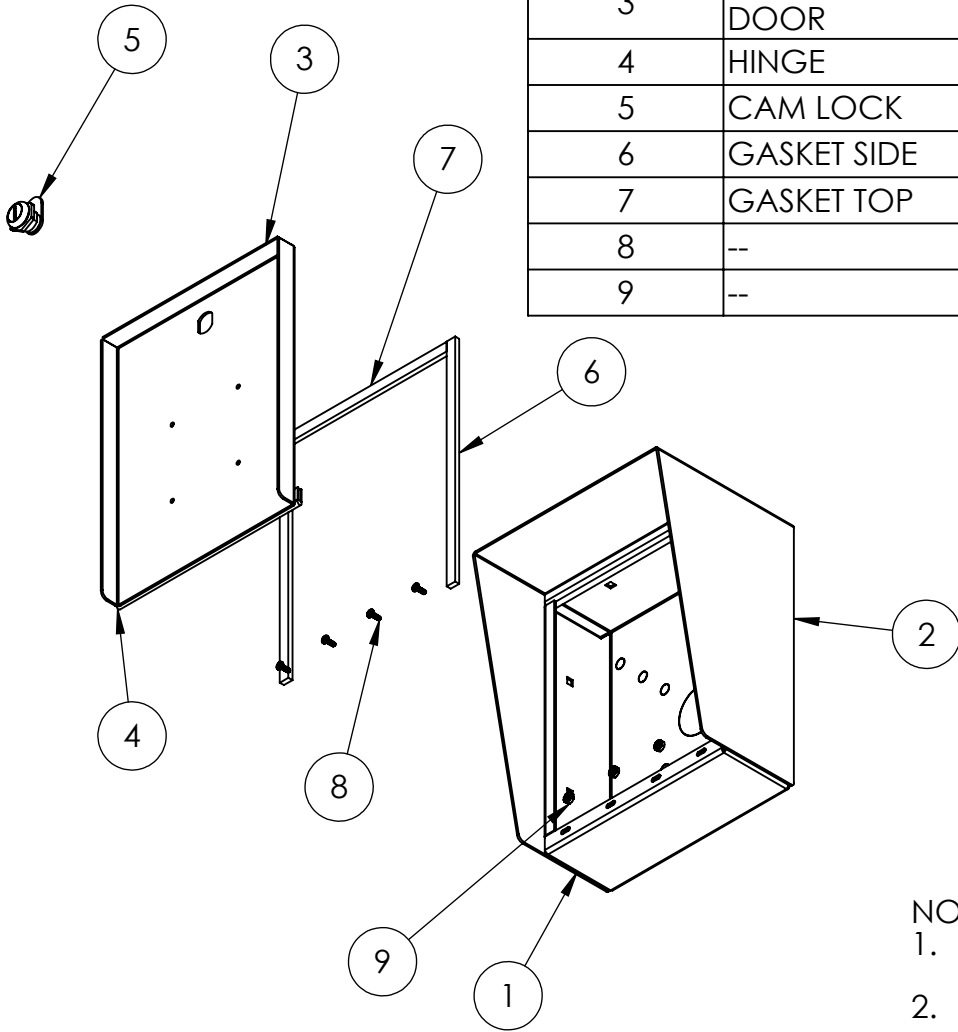

NOTES:

- SEE STANDARD PREPARATION AND COATING INSTRUCTIONS FOR COATING PROCEDURE AND COLOR.
- SEE STANDARD PACKAGING INSTRUCTIONS FOR PACKAGING PROCEDURE.

www.GooseneckStands.com  (888) 378 - 1045  Sales@GooseneckStands.com	UNLESS OTHERWISE SPECIFIED:	NAME	DATE	TITLE:	SIZE	PART NO.	REV
	DIMENSIONS ARE IN INCHES TOLERANCES: FRACTIONAL $\pm 1/32$ ANGULAR: $\pm 2^\circ$ TWO PLACE DECIMAL $\pm 0.010$ THREE PLACE DECIMAL $\pm 0.005$	DRAWN			<b>ASSEMBLY</b>	<b>A</b>	810HOU-LIFT-01-304 (KPW5)
INTERPRET GEOMETRIC TOLERANCING PER: ASME Y14.5 -2009	CHECKED			Monday, December 9, 2024 12:44:20 PM			
<b>PROPRIETARY AND CONFIDENTIAL</b> THE INFORMATION CONTAINED IN THIS DRAWING IS THE SOLE PROPERTY OF PEDESTALPRO LLC. ANY REPRODUCTION IN PART OR AS A WHOLE WITHOUT THE WRITTEN PERMISSION OF PEDESTALPRO LLC IS PROHIBITED.				WEIGHT: 10.225			