

NOTES:

1. MATERIAL OF CONSTRUCTION IS MILD STEEL.
2. 2-4 MILS BLACK WRINKLE POWDER COAT.

1. PWDR-BLACK-WRINKLE

www.GooseneckStands.com

(888) 378 - 1045

Sales@GooseneckStands.com

UNLESS OTHERWISE SPECIFIED: ★

DIMENSIONS ARE IN INCHES  
 TOLERANCES:  
 FRACTIONAL: ± 1/32  
 ANGULAR: ± 2°  
 TWO PLACE DECIMAL ± 0.010  
 THREE PLACE DECIMAL ± 0.005

INTERPRET GEOMETRIC  
 TOLERANCING PER:  
 ASME Y14.5 -2009

NAME	DATE
DRAWN	
CHECKED	

**PROPRIETARY AND CONFIDENTIAL**  
 THE INFORMATION CONTAINED IN THIS DRAWING IS THE SOLE PROPERTY OF PEDESTALPRO LLC. ANY REPRODUCTION IN PART OR AS A WHOLE WITHOUT THE WRITTEN PERMISSION OF PEDESTALPRO LLC IS PROHIBITED.

TITLE:  
**INSTALLATION**

Monday, January 13, 2025  
 2:27:08 PM

WEIGHT: 10.01

SIZE	PART NO.	REV
<b>A</b>	810HOU-AKUV-01-CRS (R20KS) NO SCALE	<b>C</b>

SHEET 1 OF 6

ITEM NO.	PART NUMBER	DESCRIPTION	QTY.
1	810HOU-AKUV-01-CRS ENCLOSURE (R20KS)	ENCLOSURE WELDMENT	1
2	810HOU-AKUV-01-CRS HOOD (R20KS)	HOOD	1
3	810HOU-AKUV-01-CRS DOOR (R20KS)	DOOR WELDMENT	1
4	HINGE	PIANO HINGE	1
5	CAM LOCK	STRAIGHT CAM	1
6	GASKET SIDE	3/8" X .150 WEATHERSTRIPPING	2
7	GASKET TOP	3/8" X .150 WEATHERSTRIPPING	1
8	--	6-32 PAN HEAD SCREW	4
9	--	6-32 EXTERNAL TOOTH LOCK NUT	4

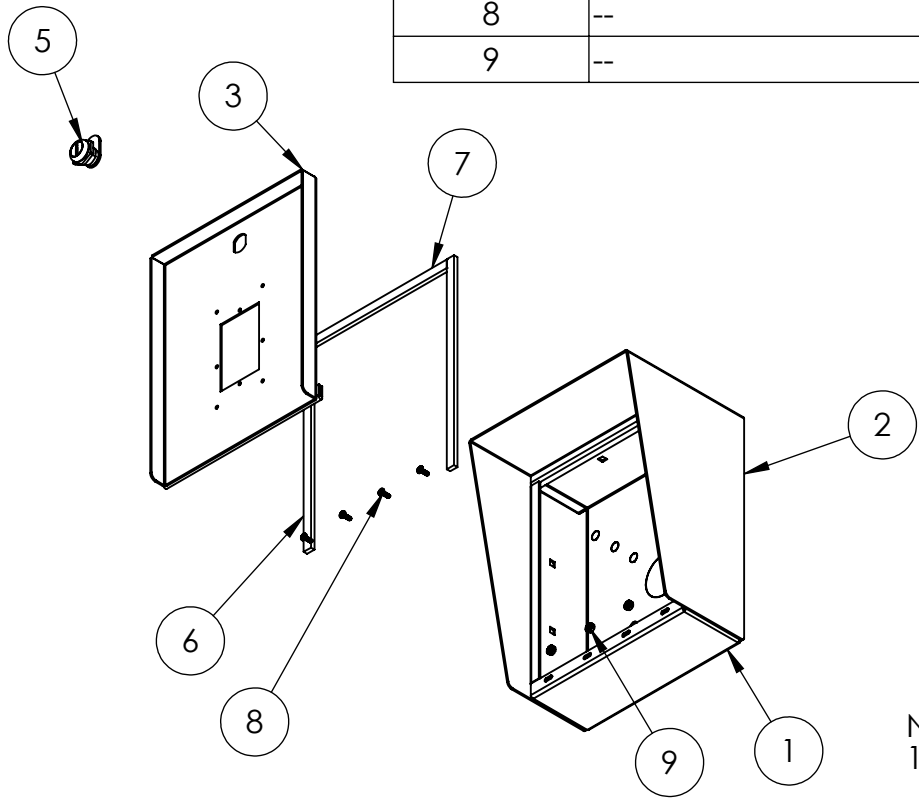

- NOTES:
- SEE STANDARD PREPARATION AND COATING INSTRUCTIONS FOR COATING PROCEDURE AND COLOR.
  - SEE STANDARD PACKAGING INSTRUCTIONS FOR PACKAGING PROCEDURE.

<a href="http://www.GooseneckStands.com">www.GooseneckStands.com</a> (888) 378 - 1045 <a href="mailto:Sales@GooseneckStands.com">Sales@GooseneckStands.com</a>	UNLESS OTHERWISE SPECIFIED:	NAME	DATE	TITLE:	SIZE	PART NO.	REV
	DIMENSIONS ARE IN INCHES TOLERANCES: FRACTIONAL $\pm 1/32$ ANGULAR: $\pm 2^\circ$ TWO PLACE DECIMAL $\pm 0.010$ THREE PLACE DECIMAL $\pm 0.005$	DRAWN			<b>ASSEMBLY</b>	<b>A</b>	810HOU-AKUV-01-CRS (R20KS)
INTERPRET GEOMETRIC TOLERANCING PER: ASME Y14.5 -2009	CHECKED			Monday, January 13, 2025 2:27:08 PM			
<b>PROPRIETARY AND CONFIDENTIAL</b> THE INFORMATION CONTAINED IN THIS DRAWING IS THE SOLE PROPERTY OF PEDESTALPRO LLC. ANY REPRODUCTION IN PART OR AS A WHOLE WITHOUT THE WRITTEN PERMISSION OF PEDESTALPRO LLC IS PROHIBITED.				WEIGHT: 9.413			