

- NOTES:
1. MATERIAL OF CONSTRUCTION IS MILD STEEL.
  2. 2-4 MILS BLACK WRINKLE POWDER COAT.  
1. PWDR-BLACK-WRINKLE

<a href="http://www.GooseneckStands.com">www.GooseneckStands.com</a>  (888) 378 - 1045  <a href="mailto:Sales@GooseneckStands.com">Sales@GooseneckStands.com</a>	UNLESS OTHERWISE SPECIFIED: ★	NAME	DATE	TITLE:			
	DIMENSIONS ARE IN INCHES TOLERANCES: FRACTIONAL $\pm 1/32$ ANGULAR: $\pm 2^\circ$ TWO PLACE DECIMAL $\pm 0.010$ THREE PLACE DECIMAL $\pm 0.005$	DRAWN			<h1 style="margin: 0;">INSTALLATION</h1>		
	INTERPRET GEOMETRIC TOLERANCING PER: ASME Y14.5 -2009	CHECKED					
<b>PROPRIETARY AND CONFIDENTIAL</b> <small>THE INFORMATION CONTAINED IN THIS DRAWING IS THE SOLE PROPERTY OF PEDESTALPRO LLC. ANY REPRODUCTION IN PART OR AS A WHOLE WITHOUT THE WRITTEN PERMISSION OF PEDESTALPRO LLC IS PROHIBITED.</small>				Monday, January 27, 2025 9:09:57 AM	SIZE <b>A</b>	PART NO. 68HOU-KERI-01-CRS	REV <b>C</b>
				WEIGHT: 1.251	NO SCALE	SHEET 1 OF 6	

ITEM NO.	PART NUMBER	DESCRIPTION	QTY.
1	68HOU-KERI-01-CRS ENCLOSURE	ENCLOSURE WELDMENT	1
2	68HOU-KERI-01-CRS DOOR	DOOR WELDMENT	1
3	68HOU-KERI-01-CRS HOOD	HOOD	1
4	HINGE	PIANO HINGE	1
5	CAM LOCK	STRAIGHT CAM	1
6	GASKET SIDE	3/8" X .150 WEATHERSTRIPPING	2
7	GASKET TOP	3/8" X .150 WEATHERSTRIPPING	1
8	--	6-32 PAN HEAD SCREW	4
9	--	6-32 EXTERNAL TOOTH LOCK NUT	4

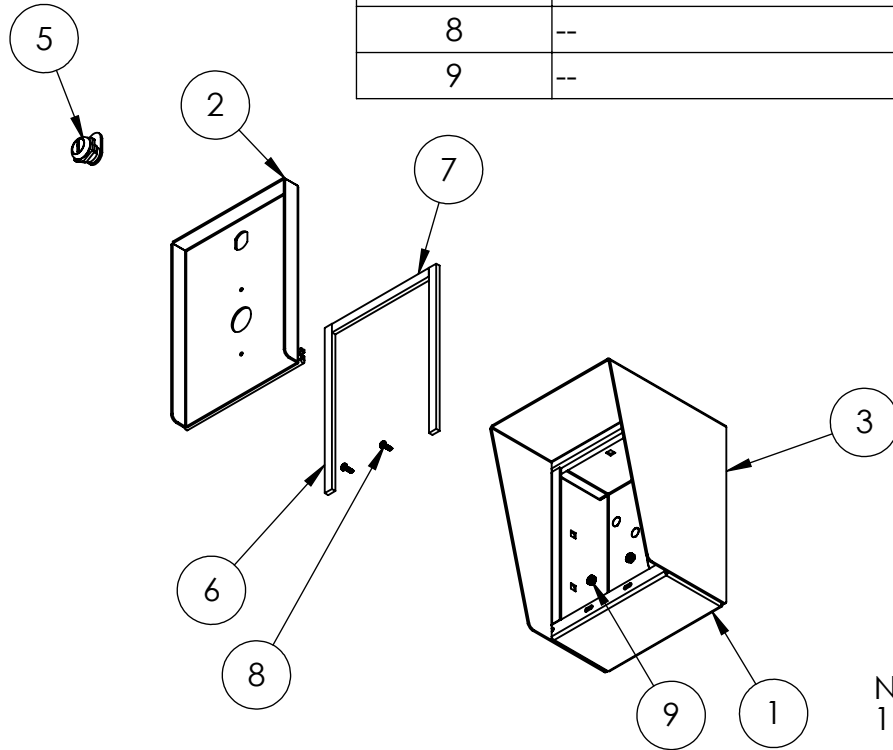

NOTES:

- SEE STANDARD PREPARATION AND COATING INSTRUCTIONS FOR COATING PROCEDURE AND COLOR.
- SEE STANDARD PACKAGING INSTRUCTIONS FOR PACKAGING PROCEDURE.

www.GooseneckStands.com

(888) 378 - 1045

Sales@GooseneckStands.com

UNLESS OTHERWISE SPECIFIED:

DIMENSIONS ARE IN INCHES  
TOLERANCES:  
FRACTIONAL  $\pm 1/32$   
ANGULAR:  $\pm 2^\circ$   
TWO PLACE DECIMAL  $\pm 0.010$   
THREE PLACE DECIMAL  $\pm 0.005$

INTERPRET GEOMETRIC  
TOLERANCING PER:  
ASME Y14.5 -2009

NAME DATE

DRAWN

CHECKED

**PROPRIETARY AND CONFIDENTIAL**

THE INFORMATION CONTAINED IN THIS  
DRAWING IS THE SOLE PROPERTY OF  
PEDESTALPRO LLC. ANY REPRODUCTION  
IN PART OR AS A WHOLE WITHOUT THE  
WRITTEN PERMISSION OF PEDESTALPRO LLC  
IS PROHIBITED.

TITLE:

**ASSEMBLY**

Monday, January 27, 2025  
9:09:57 AM

WEIGHT: 6.828

SIZE  
**A**

PART NO.  
68HOU-KERI-01-CRS

REV  
**C**

NO SCALE

SHEET 2 OF 6