

NOTES:

1. MATERIAL OF CONSTRUCTION IS MILD STEEL.
2. 2-4 MILS BLACK WRINKLE POWDER COAT.

1. PWDR-BLACK-WRINKLE

www.GooseneckStands.com (888) 378 - 1045 Sales@GooseneckStands.com	UNLESS OTHERWISE SPECIFIED: ★	NAME	DATE	TITLE:			
	DIMENSIONS ARE IN INCHES TOLERANCES: FRACTIONAL ± 1/32 ANGULAR: ± 2° TWO PLACE DECIMAL ± 0.010 THREE PLACE DECIMAL ± 0.005	DRAWN			<h1>INSTALLATION</h1>		
	INTERPRET GEOMETRIC TOLERANCING PER: ASME Y14.5 -2009	CHECKED				Monday, January 27, 2025 12:08:21 PM	SIZE A PART NO. 68HOU-EBMU-01-CRS
	PROPRIETARY AND CONFIDENTIAL THE INFORMATION CONTAINED IN THIS DRAWING IS THE SOLE PROPERTY OF PEDESTALPRO LLC. ANY REPRODUCTION IN PART OR AS A WHOLE WITHOUT THE WRITTEN PERMISSION OF PEDESTALPRO LLC IS PROHIBITED.			WEIGHT: 6.787	NO SCALE	SHEET 1 OF 7	

ITEM NO.	PART NUMBER	DESCRIPTION	QTY.
1	68HOU-EBMU-01-CRS ENCLOSURE	ENCLOSURE WELDMENT	1
2	68HOU-EBMU-01-CRS DOOR	DOOR WELDMENT	1
3	68HOU-EBMU-01-CRS HOOD	HOOD	1
4	HINGE	PIANO HINGE	1
5	GASKET SIDE	3/8" X .150 WEATHERSTRIPPING	2
6	GASKET TOP	3/8" X .150 WEATHERSTRIPPING	1
7	--	6-32 PAN HEAD SCREW	2
8	--	6-32 EXTERNAL TOOTH LOCK NUT	2
9	SFIC-LFIC LOCK BRACKET	LOCK BRACKET	1
10	--	8-32 X .375" SS PEM STUD	2
11	--	8-32 KEPS NUT	2

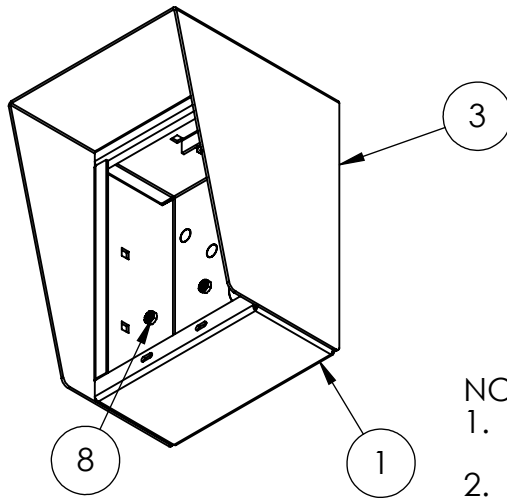
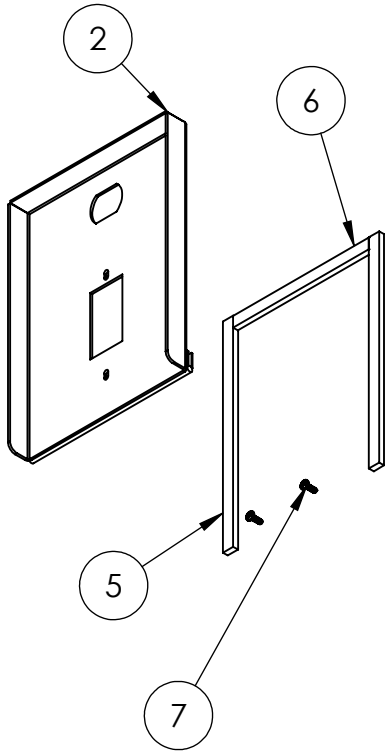

NOTES:

1. SEE STANDARD PREPARATION AND COATING INSTRUCTIONS FOR COATING PROCEDURE AND COLOR.
2. SEE STANDARD PACKAGING INSTRUCTIONS FOR PACKAGING PROCEDURE.

www.GooseneckStands.com

(888) 378 - 1045

Sales@GooseneckStands.com

UNLESS OTHERWISE SPECIFIED:

DIMENSIONS ARE IN INCHES
TOLERANCES:
FRACTIONAL $\pm 1/32$
ANGULAR: $\pm 2^\circ$
TWO PLACE DECIMAL ± 0.010
THREE PLACE DECIMAL ± 0.005

INTERPRET GEOMETRIC
TOLERANCING PER:
ASME Y14.5 -2009

NAME DATE

DRAWN

CHECKED

PROPRIETARY AND CONFIDENTIAL

THE INFORMATION CONTAINED IN THIS
DRAWING IS THE SOLE PROPERTY OF
PEDESTALPRO LLC. ANY REPRODUCTION
IN PART OR AS A WHOLE WITHOUT THE
WRITTEN PERMISSION OF PEDESTALPRO LLC
IS PROHIBITED.

TITLE:

ASSEMBLY

Monday, January 27, 2025
12:08:21 PM

WEIGHT: 6.787

SIZE
A

PART NO.

68HOU-EBMU-01-CRS

REV
C

NO SCALE

SHEET 2 OF 7