

- NOTES:
1. MATERIAL OF CONSTRUCTION IS MILD STEEL.
  2. 2-4 MILS BLACK WRINKLE POWDER COAT.
  1. PWDR-BLACK-WRINKLE

www.GooseneckStands.com

(888) 378 - 1045

Sales@GooseneckStands.com

UNLESS OTHERWISE SPECIFIED: ★  
 DIMENSIONS ARE IN INCHES  
 TOLERANCES:  
 FRACTIONAL ± 1/32  
 ANGULAR: ± 2°  
 TWO PLACE DECIMAL ± 0.010  
 THREE PLACE DECIMAL ± 0.005  
 INTERPRET GEOMETRIC  
 TOLERANCING PER:  
 ASME Y14.5 -2009

★ NAME DATE  
 DRAWN  
 CHECKED  
**PROPRIETARY AND CONFIDENTIAL**  
 THE INFORMATION CONTAINED IN THIS  
 DRAWING IS THE SOLE PROPERTY OF  
 PEDESTALPRO LLC. ANY REPRODUCTION  
 IN PART OR AS A WHOLE WITHOUT THE  
 WRITTEN PERMISSION OF PEDESTALPRO LLC  
 IS PROHIBITED.

TITLE:  
**INSTALLATION**

Thursday, October 29,  
 2020 10:51:19 AM

WEIGHT: 6.804

SIZE <b>A</b>	PART NO. 68HOU-CONT-01-CRS (CHIME POE) NO SCALE	REV <b>A</b>
		SHEET 1 OF 6

ITEM NO.	PART NUMBER	DESCRIPTION	QTY.
1	68HOU-CONT-01-CRS ENCLOSURE (CHIME POE)	ENCLOSURE WELDMENT	1
2	68HOU-CONT-01-CRS DOOR (CHIME POE)	DOOR WELDMENT	1
3	68HOU-CONT-01-CRS HOOD (CHIME POE)	HOOD	1
4	HINGE	PIANO HINGE	1
5	CAM LOCK	STRAIGHT CAM	1
6	GASKET SIDE	3/8" X .150 WEATHERSTRIPPING	2
7	GASKET TOP	3/8" X .150 WEATHERSTRIPPING	1
8	--	6-32 PAN HEAD SCREW	2
9	--	6-32 EXTERNAL TOOTH LOCK NUT	2

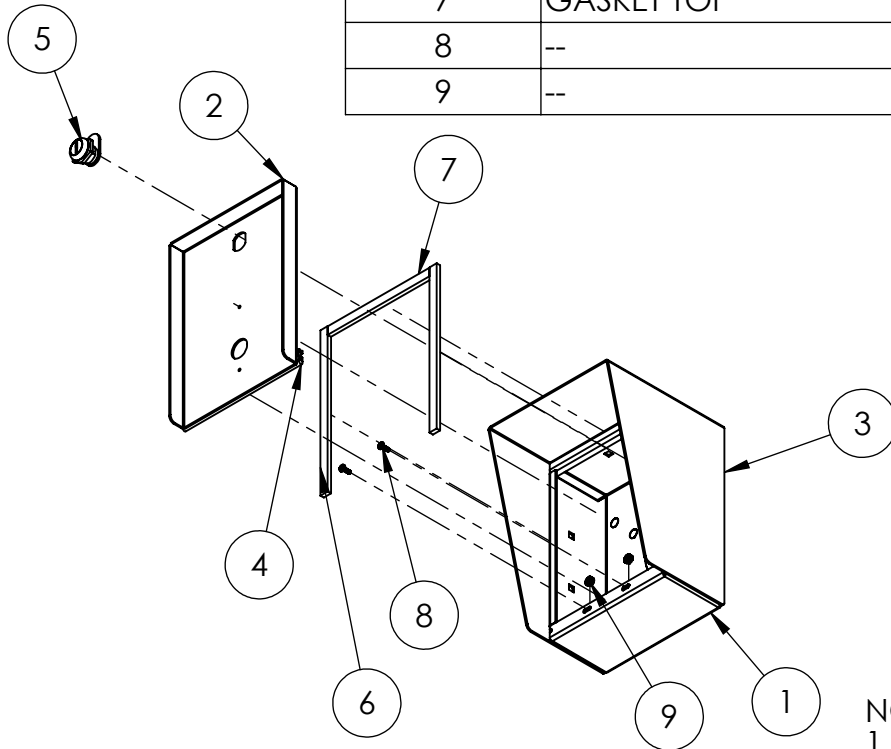

NOTES:

1. SEE STANDARD PREPARATION AND COATING INSTRUCTIONS FOR COATING PROCEDURE AND COLOR.
2. SEE STANDARD PACKAGING INSTRUCTIONS FOR PACKAGING PROCEDURE.

www.GooseneckStands.com  (888) 378 - 1045  Sales@GooseneckStands.com	UNLESS OTHERWISE SPECIFIED:	NAME	DATE	TITLE:			
	DIMENSIONS ARE IN INCHES TOLERANCES: FRACTIONAL ± 1/32 ANGULAR: ± 2° TWO PLACE DECIMAL ± 0.010 THREE PLACE DECIMAL ± 0.005	DRAWN			<b>ASSEMBLY</b>	SIZE	PART NO.
INTERPRET GEOMETRIC TOLERANCING PER: ASME Y14.5 -2009	CHECKED			Thursday, October 29, 2020 10:51:19 AM		<b>A</b>	68HOU-CONT-01-CRS (CHIME POE) NO SCALE
<b>PROPRIETARY AND CONFIDENTIAL</b> THE INFORMATION CONTAINED IN THIS DRAWING IS THE SOLE PROPERTY OF PEDESTALPRO LLC. ANY REPRODUCTION IN PART OR AS A WHOLE WITHOUT THE WRITTEN PERMISSION OF PEDESTALPRO LLC IS PROHIBITED.				WEIGHT: 6.804			SHEET 2 OF 6