

AIPHONE JP-DV

NOTES:

1. MATERIAL OF CONSTRUCTION IS MILD STEEL.
2. 2-4 MILS BLACK WRINKLE POWDER COAT.
 1. PWDR-BLACK-WRINKLE

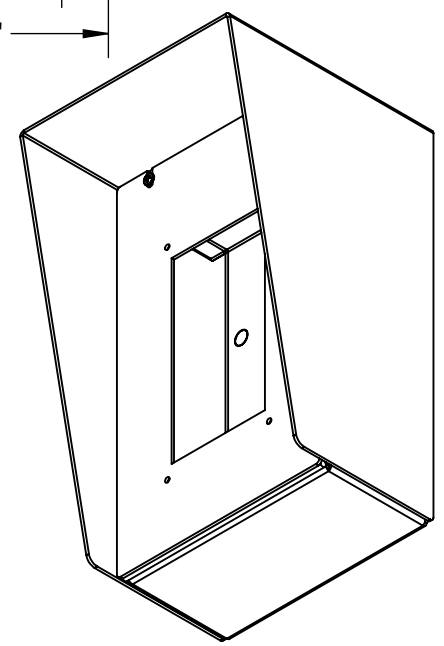

www.GooseneckStands.com
 (888) 378 - 1045
 Sales@GooseneckStands.com

UNLESS OTHERWISE SPECIFIED: ★
 DIMENSIONS ARE IN INCHES
 TOLERANCES:
 FRACTIONAL ± 1/32
 ANGULAR: ± 2°
 TWO PLACE DECIMAL ± 0.010
 THREE PLACE DECIMAL ± 0.005
 INTERPRET GEOMETRIC
 TOLERANCING PER:
 ASME Y14.5 -2009

NAME	DATE
DRAWN	
CHECKED	
PROPRIETARY AND CONFIDENTIAL	
THE INFORMATION CONTAINED IN THIS DRAWING IS THE SOLE PROPERTY OF PEDESTALPRO LLC. ANY REPRODUCTION IN PART OR AS A WHOLE WITHOUT THE WRITTEN PERMISSION OF PEDESTALPRO LLC IS PROHIBITED.	

TITLE: INSTALLATION		DATE: Monday, July 29, 2024 10:03:40 AM	SIZE: A	PART NO. 610HOU-AIPH-07-CRS	REV C
WEIGHT: 7.471		NO SCALE		SHEET 1 OF 6	

ITEM NO.	PART NUMBER	DESCRIPTION	QTY.
1	610HOU-AIPH-07-CRS ENCLOSURE	ENCLOSURE WELDMENT	1
2	610HOU-AIPH-07-CRS DOOR	DOOR WELDMENT	1
3	HINGE	PIANO HINGE	1
4	GASKET SIDE	3/8" X .150 WEATHERSTRIPPING	2
5	GASKET TOP	3/8" X .150 WEATHERSTRIPPING	1
6	--	6-32 PAN HEAD SCREW	4
7	--	6-32 EXTERNAL TOOTH LOCK NUT	2

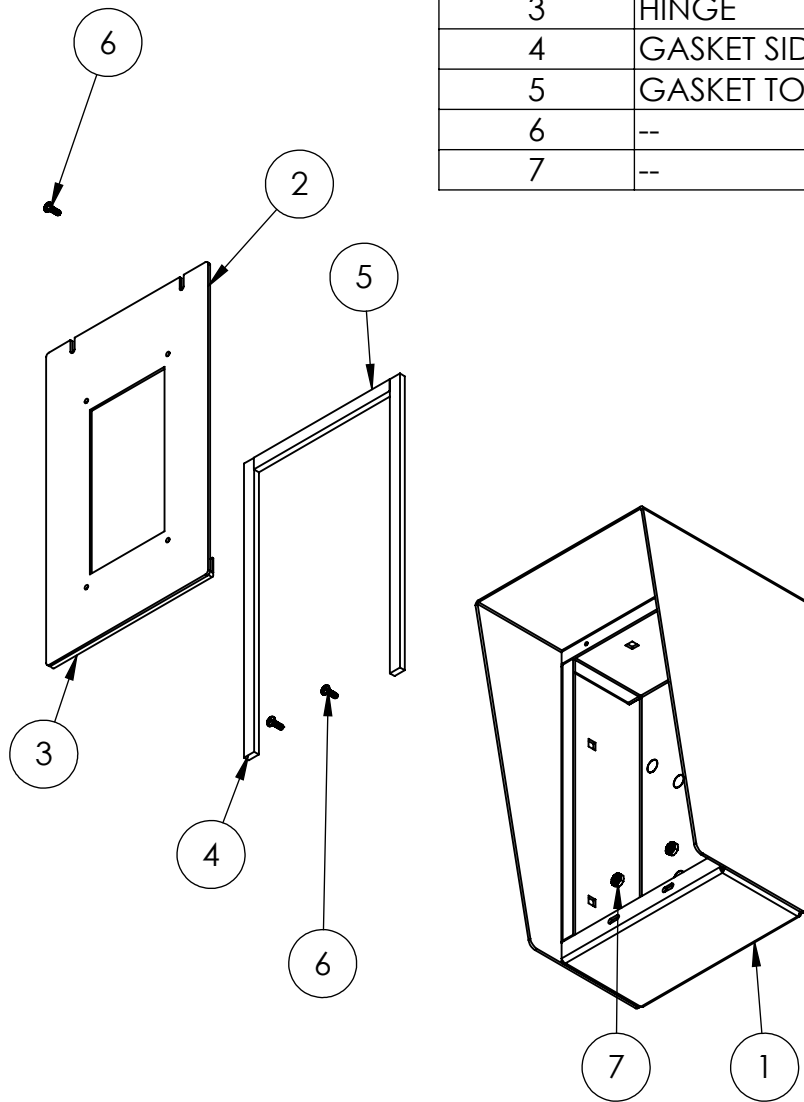

NOTES:

1. SEE STANDARD PREPARATION AND COATING INSTRUCTIONS FOR COATING PROCEDURE AND COLOR.
2. SEE STANDARD PACKAGING INSTRUCTIONS FOR PACKAGING PROCEDURE.

www.GooseneckStands.com (888) 378 - 1045 Sales@GooseneckStands.com	UNLESS OTHERWISE SPECIFIED:	NAME	DATE	TITLE:		
	DIMENSIONS ARE IN INCHES TOLERANCES: FRACTIONAL $\pm 1/32$ ANGULAR: $\pm 2^\circ$ TWO PLACE DECIMAL ± 0.010 THREE PLACE DECIMAL ± 0.005	DRAWN			ASSEMBLY	SIZE
INTERPRET GEOMETRIC TOLERANCING PER: ASME Y14.5 -2009	CHECKED			A		610HOU-AIPH-07-CRS
PROPRIETARY AND CONFIDENTIAL THE INFORMATION CONTAINED IN THIS DRAWING IS THE SOLE PROPERTY OF PEDESTALPRO LLC. ANY REPRODUCTION IN PART OR AS A WHOLE WITHOUT THE WRITTEN PERMISSION OF PEDESTALPRO LLC IS PROHIBITED.				Tuesday, September 11, 2018 9:34:19 AM		C
				WEIGHT: 7.471	NO SCALE	SHEET 2 OF 6