

- NOTES:
1. MATERIAL OF CONSTRUCTION IS MILD STEEL.
  2. 2-4 MILS BLACK WRINKLE POWDER COAT.
    1. PWDR-BLACK-WRINKLE

www.GooseneckStands.com

(888) 378 - 1045

Sales@GooseneckStands.com

UNLESS OTHERWISE SPECIFIED:

DIMENSIONS ARE IN INCHES  
 TOLERANCES:  
 FRACTIONAL  $\pm 1/32$   
 ANGULAR:  $\pm 2^\circ$   
 TWO PLACE DECIMAL  $\pm 0.010$   
 THREE PLACE DECIMAL  $\pm 0.005$

INTERPRET GEOMETRIC  
 TOLERANCING PER:  
 ASME Y14.5 -2009

NAME DATE

DRAWN

CHECKED

**PROPRIETARY AND CONFIDENTIAL**

THE INFORMATION CONTAINED IN THIS  
 DRAWING IS THE SOLE PROPERTY OF  
 PEDESTALPRO LLC. ANY REPRODUCTION  
 IN PART OR AS A WHOLE WITHOUT THE  
 WRITTEN PERMISSION OF PEDESTALPRO LLC  
 IS PROHIBITED.

TITLE:

INSTALLATION

Friday, October 11,  
 2024 11:08:02 AM

WEIGHT: 30.682

SIZE  
**A**

PART NO.  
 22PE2-EBMU-01-CRS

REV  
**A**

NO SCALE

SHEET 1 OF 5

ITEM NO.	PART NUMBER	DESCRIPTION	QTY.
1	58-9C-DSP VERTICAL	TOWER WELDMENT	1
2	PLTFAC-4-2	FACEPLATE	2
3	PLTCOV-8-2	COVER PLATE	1
4	PLTBAS-8-2	BASE PLATE	1
5	22PE2-EBMU-01-CRS ACCESS PANEL	ACCESS PANEL	1
6	--	8-32 X 1/2" 304 SS FLAT HEAD SECURITY SCREW	2
7	--	1/4-20 X .5 ZINC PL CARRIAGE BOLT	8
8	--	1/4-20 ZINC PL HEX NUT	8

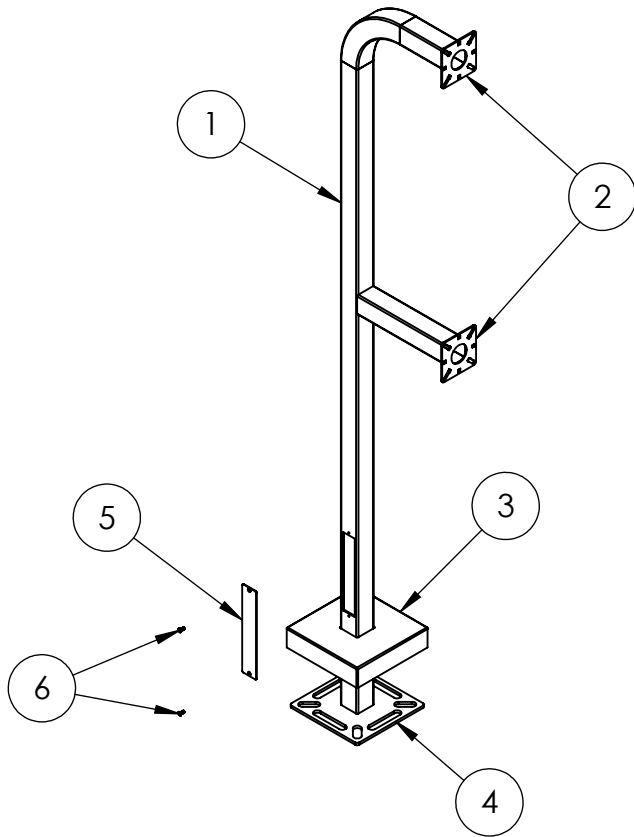

NOTES:

1. SEE STANDARD PREPARATION AND COATING INSTRUCTIONS FOR COATING PROCEDURE AND COLOR.
2. SEE STANDARD PACKAGING INSTRUCTIONS FOR PACKAGING PROCEDURE.

<a href="http://www.GooseneckStands.com">www.GooseneckStands.com</a> (888) 378 - 1045 <a href="mailto:Sales@GooseneckStands.com">Sales@GooseneckStands.com</a>	UNLESS OTHERWISE SPECIFIED:	NAME	DATE	TITLE:			
	DIMENSIONS ARE IN INCHES TOLERANCES: FRACTIONAL $\pm 1/32$ ANGULAR: $\pm 2^\circ$ TWO PLACE DECIMAL $\pm 0.010$ THREE PLACE DECIMAL $\pm 0.005$	DRAWN			<b>ASSEMBLY</b>		
INTERPRET GEOMETRIC TOLERANCING PER: ASME Y14.5 -2009	CHECKED			Friday, October 11, 2024 11:08:02 AM		SIZE <b>A</b>	PART NO. 22PE2-EBMU-01-CRS
PROPRIETARY AND CONFIDENTIAL THE INFORMATION CONTAINED IN THIS DRAWING IS THE SOLE PROPERTY OF PEDESTALPRO LLC. ANY REPRODUCTION IN PART OR AS A WHOLE WITHOUT THE WRITTEN PERMISSION OF PEDESTALPRO LLC IS PROHIBITED.				WEIGHT: 30.682	NO SCALE	SHEET 2 OF 5	