

NOTES:
 1. MATERIAL OF CONSTRUCTION IS 304 SS, BRUSHED #4.

www.GooseneckStands.com

(888) 378 - 1045

Sales@GooseneckStands.com

UNLESS OTHERWISE SPECIFIED:

DIMENSIONS ARE IN INCHES
 TOLERANCES:
 FRACTIONAL $\pm 1/32$
 ANGULAR: $\pm 2^\circ$
 TWO PLACE DECIMAL ± 0.010
 THREE PLACE DECIMAL ± 0.005

INTERPRET GEOMETRIC
 TOLERANCING PER:
 ASME Y14.5 -2009

NAME DATE

DRAWN

CHECKED

PROPRIETARY AND CONFIDENTIAL

THE INFORMATION CONTAINED IN THIS
 DRAWING IS THE SOLE PROPERTY OF
 PEDESTALPRO LLC. ANY REPRODUCTION
 IN PART OR AS A WHOLE WITHOUT THE
 WRITTEN PERMISSION OF PEDESTALPRO LLC
 IS PROHIBITED.

TITLE:

INSTALLATION

Friday, October 11,
 2024 11:06:51 AM

WEIGHT: 31.343

SIZE
A

PART NO.
 22PE2-EBMU-01-304

REV
A

NO SCALE

SHEET 1 OF 5

ITEM NO.	PART NUMBER	DESCRIPTION	QTY.
1	58-9C-DSP VERTICAL	TOWER WELDMENT	1
2	PLTFAC-4-2	FACEPLATE	2
3	PLTCOV-8-2	COVER PLATE	1
4	PLTBAS-8-2	BASE PLATE	1
5	22PE2-EBMU-01-304 ACCESS PANEL	ACCESS PANEL	1
6	--	8-32 X 1/2" FLAT HEAD SECURITY SCREW	2
7	--	1/4-20 X .5 ZINC PL CARRIAGE BOLT	8
8	--	1/4-20 ZINC PL HEX NUT	8

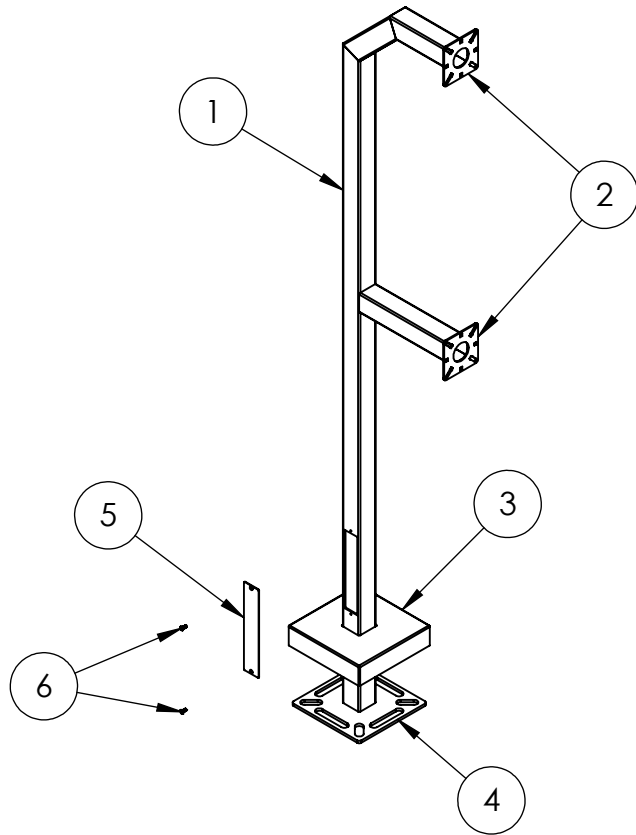

NOTES:

- SEE STANDARD PREPARATION AND COATING INSTRUCTIONS FOR COATING PROCEDURE AND COLOR.
- SEE STANDARD PACKAGING INSTRUCTIONS FOR PACKAGING PROCEDURE.

www.GooseneckStands.com (888) 378 - 1045 Sales@GooseneckStands.com	UNLESS OTHERWISE SPECIFIED:	NAME	DATE	TITLE:			
	DIMENSIONS ARE IN INCHES TOLERANCES: FRACTIONAL $\pm 1/32$ ANGULAR: $\pm 2^\circ$ TWO PLACE DECIMAL ± 0.010 THREE PLACE DECIMAL ± 0.005	DRAWN			ASSEMBLY		
INTERPRET GEOMETRIC TOLERANCING PER: ASME Y14.5 -2009	CHECKED			Friday, October 11, 2024 11:06:51 AM		SIZE A	PART NO. 22PE2-EBMU-01-304
PROPRIETARY AND CONFIDENTIAL THE INFORMATION CONTAINED IN THIS DRAWING IS THE SOLE PROPERTY OF PEDESTALPRO LLC. ANY REPRODUCTION IN PART OR AS A WHOLE WITHOUT THE WRITTEN PERMISSION OF PEDESTALPRO LLC IS PROHIBITED.				WEIGHT: 31.343	NO SCALE	SHEET 2 OF 5	