

- NOTES:
1. MATERIAL OF CONSTRUCTION IS MILD STEEL.
 2. 2-4 MILS BLACK WRINKLE POWDER COAT.

www.GooseneckStands.com (888) 378 - 1045 Sales@GooseneckStands.com	UNLESS OTHERWISE SPECIFIED:	NAME	DATE	TITLE:		
	DIMENSIONS ARE IN INCHES TOLERANCES: FRACTIONAL $\pm 1/32$ ANGULAR: $\pm 2^\circ$ TWO PLACE DECIMAL ± 0.010 THREE PLACE DECIMAL ± 0.005	DRAWN			INSTALLATION	
INTERPRET GEOMETRIC TOLERANCING PER: ASME Y14.5 -2009	CHECKED			Monday, January 6, 2025 3:11:59 PM		SIZE A
THE INFORMATION CONTAINED IN THIS DRAWING IS THE SOLE PROPERTY OF PEDESTALPRO LLC. ANY REPRODUCTION IN PART OR AS A WHOLE WITHOUT THE WRITTEN PERMISSION OF PEDESTALPRO LLC IS PROHIBITED.		PROPRIETARY AND CONFIDENTIAL		WEIGHT: 21.237	REV A	
						SHEET 1 OF 7

ITEM NO.	PART NUMBER	DESCRIPTION	QTY.
1	22PE1-VALE-01-CRS (10 IN INTERCOM)	TOWER WELDMENT	1
2	22PE1-VALE-01-CRS (10 IN INTERCOM) FACE PLATE	FACE PLATE	1
3	22PE1-VALE-01-CRS (10 IN INTERCOM) BACK PLATE	BACK PLATE	1
4	PLTCOV-5-2	COVER PLATE	1
5	PLTBAS-5-2	BASE PLATE	1

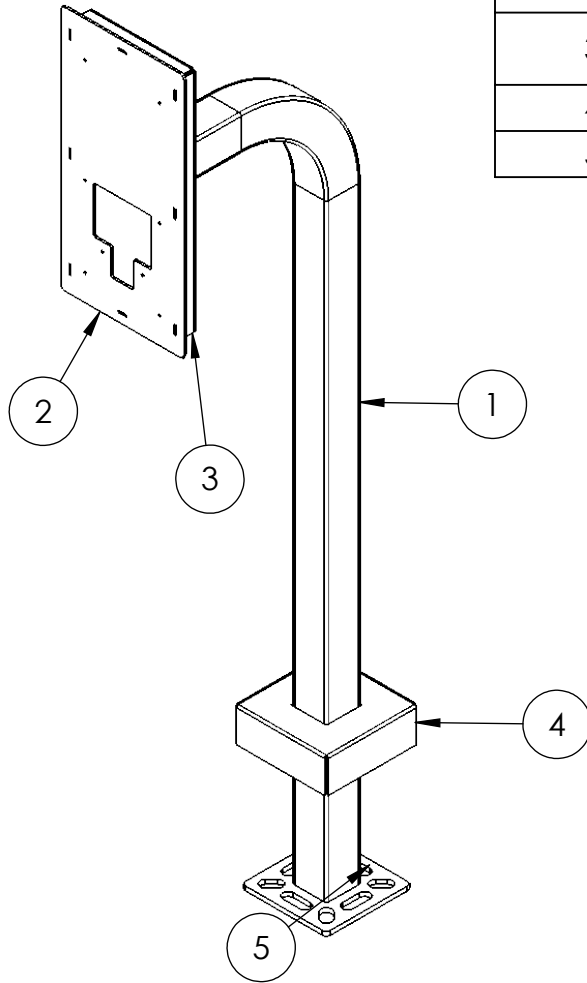

NOTES:

1. SEE STANDARD PREPARATION AND COATING INSTRUCTIONS FOR COATING PROCEDURE AND COLOR.
2. SEE STANDARD PACKAGING INSTRUCTIONS FOR PACKAGING PROCEDURE.

www.GooseneckStands.com (888) 378 - 1045 Sales@GooseneckStands.com	UNLESS OTHERWISE SPECIFIED:	NAME	DATE	TITLE:			
	DIMENSIONS ARE IN INCHES TOLERANCES: FRACTIONAL $\pm 1/32$ ANGULAR: $\pm 2^\circ$ TWO PLACE DECIMAL ± 0.010 THREE PLACE DECIMAL ± 0.005	DRAWN			ASSEMBLY	SIZE	PART NO.
INTERPRET GEOMETRIC TOLERANCING PER: ASME Y14.5 -2009	CHECKED			Monday, January 6, 2025 3:11:59 PM		A	22PE1-VALE-01-CRS (10 IN INTERCOM) NO SCALE
	PROPRIETARY AND CONFIDENTIAL THE INFORMATION CONTAINED IN THIS DRAWING IS THE SOLE PROPERTY OF PEDESTALPRO LLC. ANY REPRODUCTION IN PART OR AS A WHOLE WITHOUT THE WRITTEN PERMISSION OF PEDESTALPRO LLC IS PROHIBITED.	WEIGHT: 21.237				SHEET 2 OF 7	