

NOTES:

1. MATERIAL OF CONSTRUCTION IS MILD STEEL.
2. 2-4 MILS BLACK WRINKLE POWDER COAT.
1. PWDR-BLACK-WRINKLE

www.GooseneckStands.com (888) 378 - 1045 Sales@GooseneckStands.com	UNLESS OTHERWISE SPECIFIED:	NAME	DATE	TITLE: INSTALLATION
	DIMENSIONS ARE IN INCHES TOLERANCES: FRACTIONAL $\pm 1/32$ ANGULAR: $\pm 2^\circ$ TWO PLACE DECIMAL ± 0.010 THREE PLACE DECIMAL ± 0.005	DRAWN		
	INTERPRET GEOMETRIC TOLERANCING PER: ASME Y14.5 -2009	CHECKED		
		PROPRIETARY AND CONFIDENTIAL		
		THE INFORMATION CONTAINED IN THIS DRAWING IS THE SOLE PROPERTY OF PEDESTALPRO LLC. ANY REPRODUCTION IN PART OR AS A WHOLE WITHOUT THE WRITTEN PERMISSION OF PEDESTALPRO LLC IS PROHIBITED.		Wednesday, January 22, 2025 8:03:20 AM
		WEIGHT: 16.655	SIZE A	PART NO. 22PE1-LIFT-01-CRS (KPW5) NO SCALE
				REV A SHEET 1 OF 7

ITEM NO.	PART NUMBER	DESCRIPTION	QTY.
1	22PE1-LIFT-01-CRS (KPW5)	TOWER WELDMENT	1
2	22PE1-LIFT-01-CRS (KPW5) BACK PLATE	BACK PLATE	1
3	22PE1-LIFT-01-CRS (KPW5) FACE PLATE	FACE PLATE	1
4	PLTBAS-5-2	BASE PLATE	1
5	PLTCOV-5-2	COVER PLATE	1

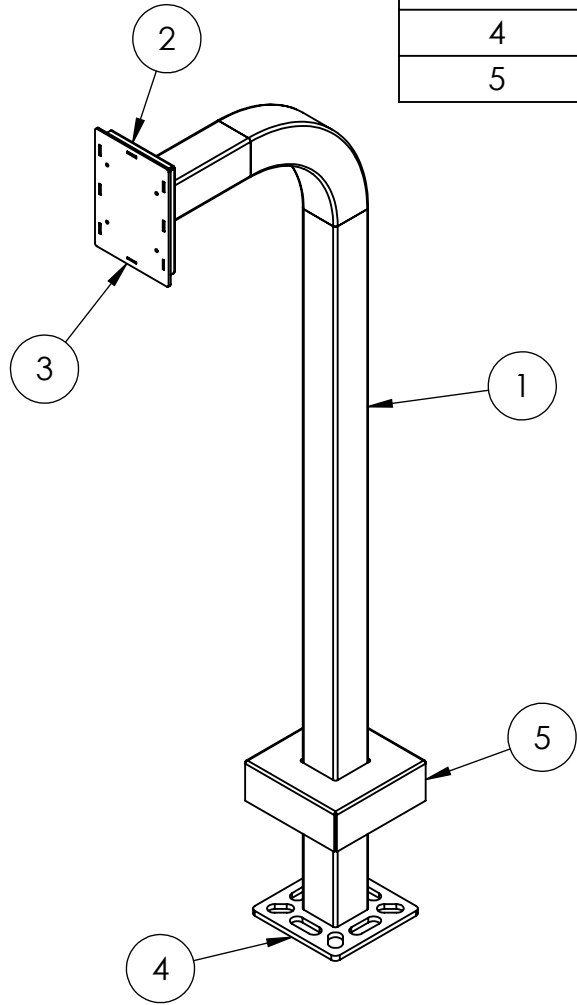

NOTES:

1. SEE STANDARD PREPARATION AND COATING INSTRUCTIONS FOR COATING PROCEDURE AND COLOR.
2. SEE STANDARD PACKAGING INSTRUCTIONS FOR PACKAGING PROCEDURE.

www.GooseneckStands.com (888) 378 - 1045 Sales@GooseneckStands.com	UNLESS OTHERWISE SPECIFIED:	NAME	DATE	TITLE:			
	DIMENSIONS ARE IN INCHES TOLERANCES: FRACTIONAL $\pm 1/32$ ANGULAR: $\pm 2^\circ$ TWO PLACE DECIMAL ± 0.010 THREE PLACE DECIMAL ± 0.005	DRAWN			ASSEMBLY	SIZE	PART NO.
INTERPRET GEOMETRIC TOLERANCING PER: ASME Y14.5 -2009	CHECKED			Wednesday, January 22, 2025 8:03:20 AM		A	22PE1-LIFT-01-CRS (KPW5) NO SCALE
<p align="center">PROPRIETARY AND CONFIDENTIAL</p> <p>THE INFORMATION CONTAINED IN THIS DRAWING IS THE SOLE PROPERTY OF PEDESTALPRO LLC. ANY REPRODUCTION IN PART OR AS A WHOLE WITHOUT THE WRITTEN PERMISSION OF PEDESTALPRO LLC IS PROHIBITED.</p>				WEIGHT: 16.655			SHEET 2 OF 7