

- NOTES:
1. MATERIAL OF CONSTRUCTION IS MILD STEEL.
  2. 2-4 MILS BLACK WRINKLE POWDER COAT.
  1. PWDR-BLACK-WRINKLE

www.GooseneckStands.com  
 (888) 378 - 1045  
 Sales@GooseneckStands.com

UNLESS OTHERWISE SPECIFIED:  
 DIMENSIONS ARE IN INCHES  
 TOLERANCES:  
 FRACTIONAL: ± 1/32  
 ANGULAR: ± 2°  
 TWO PLACE DECIMAL ± 0.010  
 THREE PLACE DECIMAL ± 0.005  
 INTERPRET GEOMETRIC TOLERANCING PER: ASME Y14.5 -2009

NAME	DATE
DRAWN	
CHECKED	
<b>PROPRIETARY AND CONFIDENTIAL</b>	
THE INFORMATION CONTAINED IN THIS DRAWING IS THE SOLE PROPERTY OF PEDESTALPRO LLC. ANY REPRODUCTION IN PART OR AS A WHOLE WITHOUT THE WRITTEN PERMISSION OF PEDESTALPRO LLC IS PROHIBITED.	

TITLE: <b>INSTALLATION</b>		DATE: Thursday, October 31, 2024 11:21:00 AM	SIZE: <b>A</b>	PART NO.: 22PE1-EBMU-02-CRS	REV: <b>A</b>
WEIGHT: 17.757		NO SCALE		SHEET 1 OF 5	

ITEM NO.	PART NUMBER	DESCRIPTION	QTY.
1	22PE1-EBMU-02-CRS	TOWER WELDMENT	1
2	PLTFAC-4-2	FACEPLATE	1
3	PLTCOV-5-2	COVER PLATE	1
4	PLTBAS-5-2	BASE PLATE	1
5	22PE1-EBMU-02-CRS ACCESS PANEL	ACCESS PANEL	1
6	--	8-32 X 1/2" 304 SS FLAT HEAD SECURITY SCREW	2
7	--	1/4-20 X .5 ZINC PL CARRIAGE BOLT	4
8	--	1/4-20 ZINC PL HEX NUT	4

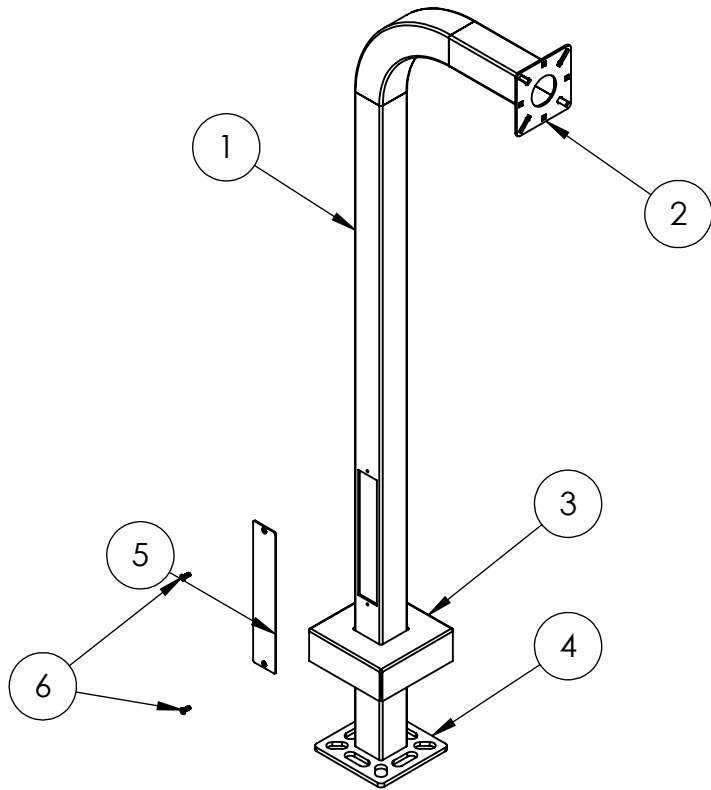

NOTES:

- SEE STANDARD PREPARATION AND COATING INSTRUCTIONS FOR COATING PROCEDURE AND COLOR.
- SEE STANDARD PACKAGING INSTRUCTIONS FOR PACKAGING PROCEDURE.

www.GooseneckStands.com  (888) 378 - 1045  Sales@GooseneckStands.com	UNLESS OTHERWISE SPECIFIED:	NAME	DATE	TITLE:			
	DIMENSIONS ARE IN INCHES TOLERANCES: FRACTIONAL $\pm 1/32$ ANGULAR: $\pm 2^\circ$ TWO PLACE DECIMAL $\pm 0.010$ THREE PLACE DECIMAL $\pm 0.005$	DRAWN			<b>ASSEMBLY</b>	SIZE	PART NO.
INTERPRET GEOMETRIC TOLERANCING PER: ASME Y14.5 -2009	CHECKED			Thursday, October 31, 2024 11:21:00 AM		<b>A</b>	22PE1-EBMU-02-CRS
<p align="center"><b>PROPRIETARY AND CONFIDENTIAL</b></p> <p>THE INFORMATION CONTAINED IN THIS DRAWING IS THE SOLE PROPERTY OF PEDESTALPRO LLC. ANY REPRODUCTION IN PART OR AS A WHOLE WITHOUT THE WRITTEN PERMISSION OF PEDESTALPRO LLC IS PROHIBITED.</p>				WEIGHT: 17.757	NO SCALE	SHEET 2 OF 5	