

AIPHONE AX-DV-P

DETAIL A

- NOTES:
1. MATERIAL OF CONSTRUCTION IS MILD STEEL.
 2. 2-4 MILS BLACK WRINKLE POWDER COAT.
 1. PWDR-BLACK-WRINKLE

<p>www.GooseneckStands.com</p> <p>(888) 378 - 1045</p> <p>Sales@GooseneckStands.com</p>	UNLESS OTHERWISE SPECIFIED:	NAME	DATE	TITLE:				
	DIMENSIONS ARE IN INCHES TOLERANCES: FRACTIONAL $\pm 1/32$ ANGULAR: $\pm 2^\circ$ TWO PLACE DECIMAL ± 0.010 THREE PLACE DECIMAL ± 0.005	DRAWN			<p>INSTALLATION</p> <p>Tuesday, August 27, 2024 10:31:37 AM</p> <p>WEIGHT: 18.781</p>	SIZE	PART NO.	REV
	INTERPRET GEOMETRIC TOLERANCING PER: ASME Y14.5 -2009	CHECKED				A	22PE1-AIPH-02-CRS	A
<p>PROPRIETARY AND CONFIDENTIAL</p> <p>THE INFORMATION CONTAINED IN THIS DRAWING IS THE SOLE PROPERTY OF PEDESTALPRO LLC. ANY REPRODUCTION IN PART OR AS A WHOLE WITHOUT THE WRITTEN PERMISSION OF PEDESTALPRO LLC IS PROHIBITED.</p>					NO SCALE	SHEET 1 OF 6		

ITEM NO.	PART NUMBER	DESCRIPTION	QTY.
1	22PE1-AIPH-02-CRS	TOWER WELDMENT	1
2	AX-DV-P FACE PLATE	FACE PLATE	1
3	AX-DV-P BACK PLATE	BACK PLATE	1
4	PLTCOV-5-2	COVER PLATE	1
5	PLTBAS-5-2	BASE PLATE	1

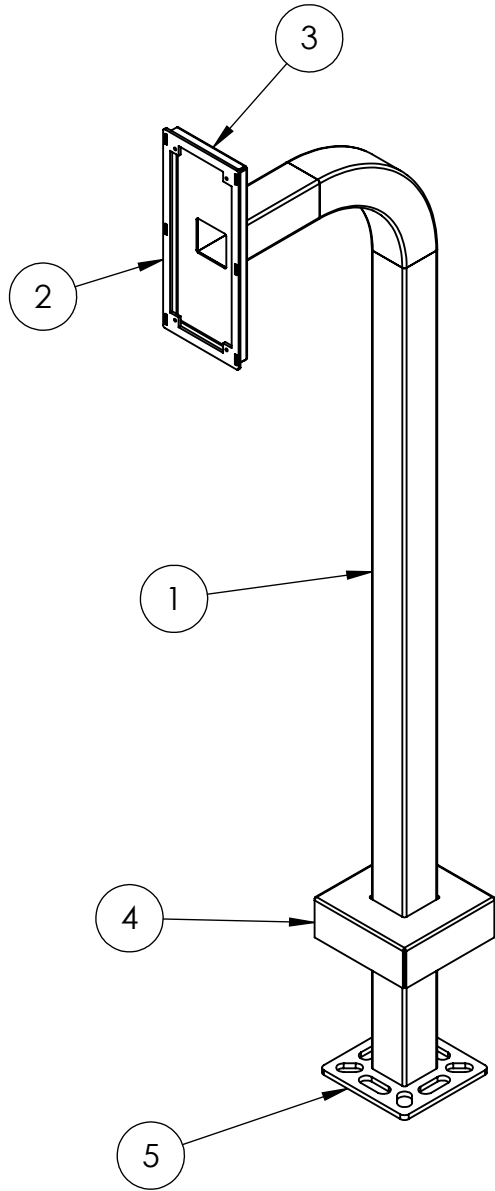

NOTES:

- SEE STANDARD PREPARATION AND COATING INSTRUCTIONS FOR COATING PROCEDURE AND COLOR.
- SEE STANDARD PACKAGING INSTRUCTIONS FOR PACKAGING PROCEDURE.

www.GooseneckStands.com (888) 378 - 1045 Sales@GooseneckStands.com	UNLESS OTHERWISE SPECIFIED:	NAME	DATE	TITLE:			
	DIMENSIONS ARE IN INCHES TOLERANCES: FRACTIONAL $\pm 1/32$ ANGULAR: $\pm 2^\circ$ TWO PLACE DECIMAL ± 0.010 THREE PLACE DECIMAL ± 0.005	DRAWN			ASSEMBLY	SIZE	PART NO.
INTERPRET GEOMETRIC TOLERANCING PER: ASME Y14.5 -2009	CHECKED			Tuesday, August 27, 2024 10:31:37 AM		A	22PE1-AIPH-02-CRS
PROPRIETARY AND CONFIDENTIAL THE INFORMATION CONTAINED IN THIS DRAWING IS THE SOLE PROPERTY OF PEDESTALPRO LLC. ANY REPRODUCTION IN PART OR AS A WHOLE WITHOUT THE WRITTEN PERMISSION OF PEDESTALPRO LLC IS PROHIBITED.				WEIGHT: 18.781	NO SCALE	SHEET 2 OF 6	