

NOTES:

1. MATERIAL OF CONSTRUCTION IS ALUMINUM.
2. COATED IN 2-4 MILS OF GLOSS BLUE POWDER COATING.
3. INTERCOM, CAMERAS, ETC. TO BE PROVIDED BY CUSTOMER.
4. LIGHTING REQUIRES CONNECTION TO INTERCOM FOR ACTIVATION.

www.GooseneckStands.com (888) 378 - 1045 Sales@GooseneckStands.com	UNLESS OTHERWISE SPECIFIED:	NAME	DATE	TITLE:			
	DIMENSIONS ARE IN INCHES TOLERANCES: FRACTIONAL ± 1/32 ANGULAR: ± 2° TWO PLACE DECIMAL ± 0.010 THREE PLACE DECIMAL ± 0.005	DRAWN			INSTALLATION	SIZE	PART NO.
INTERPRET GEOMETRIC TOLERANCING PER: ASME Y14.5 -2009	CHECKED			THURSDAY, DECEMBER 12, 2024 1:47:25 PM		A	156STA-VERK-02-ALU
<p align="center">PROPRIETARY AND CONFIDENTIAL</p> <p>THE INFORMATION CONTAINED IN THIS DRAWING IS THE SOLE PROPERTY OF PEDESTALPRO LLC. ANY REPRODUCTION IN PART OR AS A WHOLE WITHOUT THE WRITTEN PERMISSION OF PEDESTALPRO LLC IS PROHIBITED.</p>				WEIGHT: 20.997	NO SCALE	SHEET 1 OF 14	

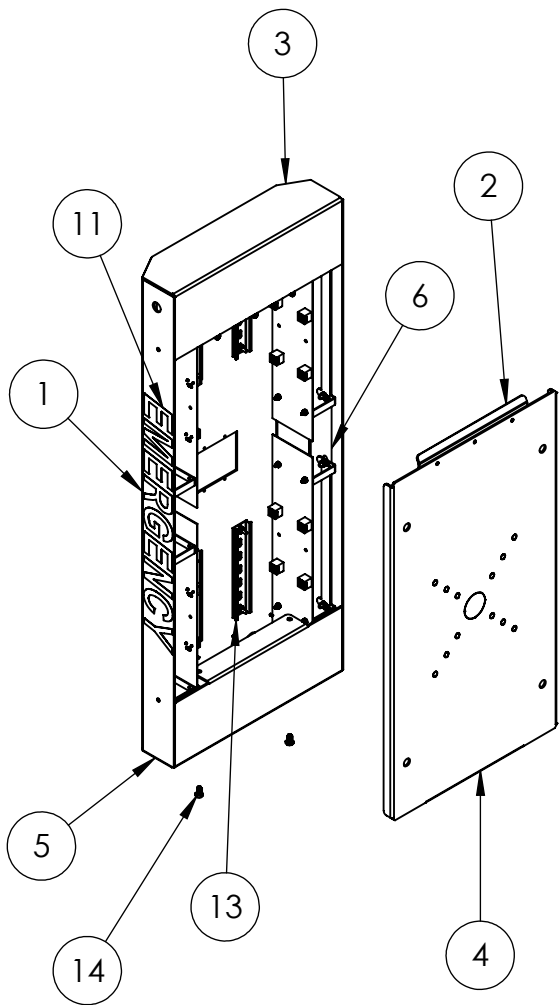

ITEM NO.	PART NUMBER	DESCRIPTION	QTY.
1	156STA-VERK-02-ALU BODY		1
2	156STA-VERK-02-ALU HOOK	WALL BRACKET HOOK	1
3	156STA-VERK-02-ALU CAP	TOP CAP	1
4	156STA-VERK-02-ALU MOUNT	WALL MOUNTING BRACKET	1
5	156STA-VERK-02-ALU BOTTOM	BOTTOM CAP	1
6	156STA-VERK-02-ALU POLYCARBONATE	FROSTED POLYCARBONATE WINDOW	2
7	BLUE BRICK LIGHT	BLUE STROBE LED LIGHT	4
8	BRA113-EMER-01-304	LED LIGHT BRACKET	4
9	SMALL EMERGENCY DECAL	WHITE REFLECTIVE VINYL	1
10	PUSH FOR HELP DECAL	WHITE REFLECTIVE VINYL	1
11	STATION EMERGENCY DECAL	WHITE REFLECTIVE VINYL	2
12	--	4-40 X 1/2 SS PAN HD SCREWS	16
13	--	DIN MOUNTING RAIL	4
14	--	1/4-20 X 1/2" HHCS	2
15	--	10-24 X .75" SS PEM STUD	16
16	--	10-24 STAINLESS STEEL KEPS NUT	16
17	--	6-32 X 1/2" SS WELD STUD	16
18	--	6-32 SS NYLON LOCK NUT	16
19	--	8-32 X 1/2 SS PEM STUD	3
20	--	8-32 SS NYLON LOCK NUT	3

NOTES:

1. SEE STANDARD PREPARATION AND COATING INSTRUCTIONS FOR COATING PROCEDURE AND COLOR.
2. SEE STANDARD PACKAGING INSTRUCTIONS FOR PACKAGING PROCEDURE.

www.GooseneckStands.com (888) 378 - 1045 Sales@GooseneckStands.com	UNLESS OTHERWISE SPECIFIED:	NAME	DATE	TITLE:		
	DIMENSIONS ARE IN INCHES TOLERANCES: FRACTIONAL ± 1/32 ANGULAR: ± 2° TWO PLACE DECIMAL ± 0.010 THREE PLACE DECIMAL ± 0.005	DRAWN			ASSEMBLY	SIZE
PROPRIETARY AND CONFIDENTIAL THE INFORMATION CONTAINED IN THIS DRAWING IS THE SOLE PROPERTY OF PEDESTALPRO LLC. ANY REPRODUCTION IN PART OR AS A WHOLE WITHOUT THE WRITTEN PERMISSION OF PEDESTALPRO LLC IS PROHIBITED.	CHECKED			THURSDAY, DECEMBER 12, 2024 1:47:25 PM		A
INTERPRET GEOMETRIC TOLERANCING PER: ASME Y14.5 -2009				WEIGHT: 20.997	NO SCALE	REV A
						SHEET 2 OF 14