

SECTION A-A

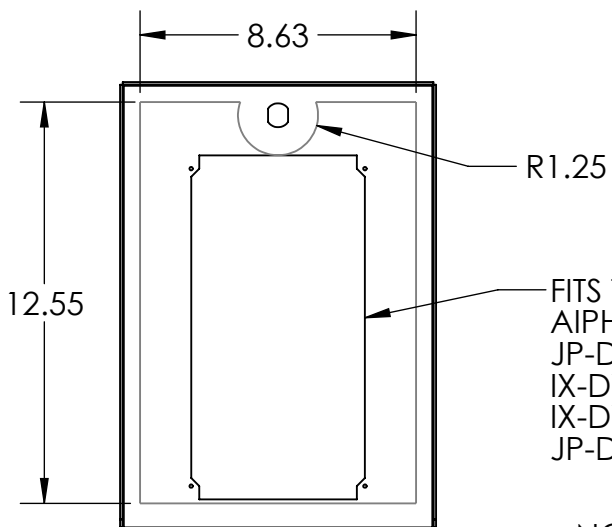
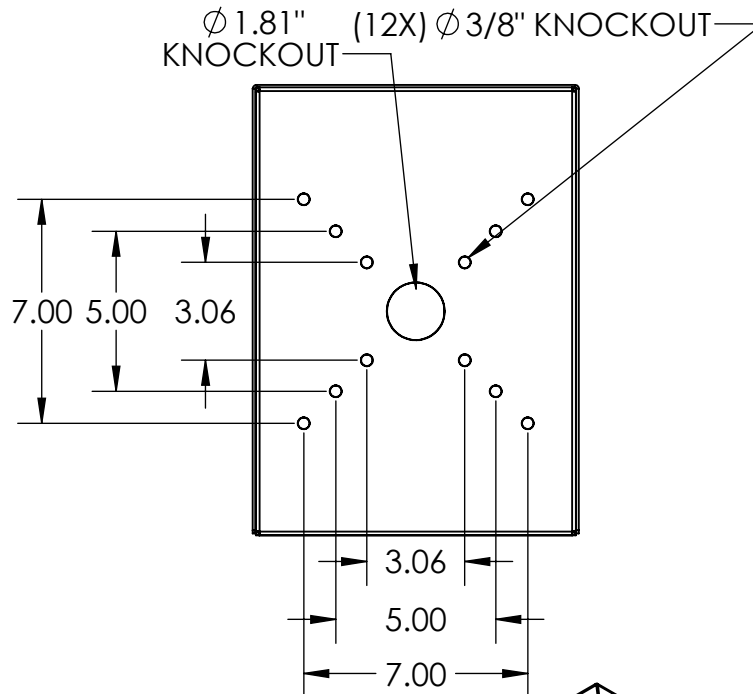

AVAILABLE CUTOUT AREA

FITS THE FOLLOWING AIPHONE PRODUCTS:
 JP-DVF-RP10
 IX-DVF-2RA
 IX-DVF-P
 JP-DVF-HID

NOTES:

1. MATERIAL OF CONSTRUCTION IS 304 SS, BRUSHED #4.

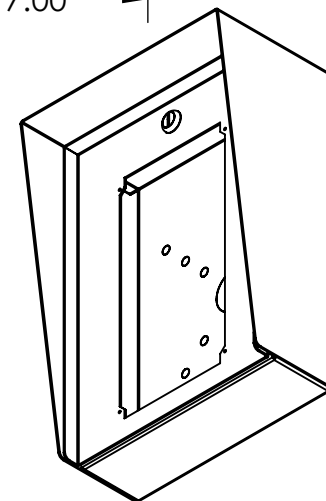

www.GooseneckStands.com (888) 378 - 1045 Sales@GooseneckStands.com	UNLESS OTHERWISE SPECIFIED: ★ DIMENSIONS ARE IN INCHES TOLERANCES: FRACTIONAL ± 1/32 ANGULAR: ± 2° TWO PLACE DECIMAL ± 0.010 THREE PLACE DECIMAL ± 0.005	NAME DATE	TITLE: <h1>INSTALLATION</h1>						
	INTERPRET GEOMETRIC TOLERANCING PER: ASME Y14.5 -2009	DRAWN CHECKED PROPRIETARY AND CONFIDENTIAL THE INFORMATION CONTAINED IN THIS DRAWING IS THE SOLE PROPERTY OF PEDESTALPRO LLC. ANY REPRODUCTION IN PART OR AS A WHOLE WITHOUT THE WRITTEN PERMISSION OF PEDESTALPRO LLC IS PROHIBITED.	Wednesday, March 19, 2025 9:27:00 AM WEIGHT: 13.874	<table border="1"> <tr> <td>SIZE A</td> <td>PART NO. 1014HOU-AIPH-04-304</td> <td>REV A</td> </tr> <tr> <td colspan="2">NO SCALE</td> <td>SHEET 1 OF 6</td> </tr> </table>	SIZE A	PART NO. 1014HOU-AIPH-04-304	REV A	NO SCALE	
SIZE A	PART NO. 1014HOU-AIPH-04-304	REV A							
NO SCALE		SHEET 1 OF 6							

ITEM NO.	PART NUMBER	DESCRIPTION	QTY.
1	1014HOU-AIPH-04-304 ENCLOSURE	ENCLOSURE WELDMENT	1
2	1014HOU-AIPH-04-304 DOOR	DOOR WELDMENT	1
3	1014HOU-AIPH-04-304 HOOD	HOOD	1
4	HINGE	PIANO HINGE	1
5	CAM LOCK	STRAIGHT CAM	1
6	GASKET SIDE	3/8" X .150 WEATHERSTRIPPING	2
7	GASKET TOP	3/8" X .150 WEATHERSTRIPPING	1
8	--	6-32 PAN HEAD SCREW	4
9	--	6-32 EXTERNAL TOOTH LOCK NUT	4

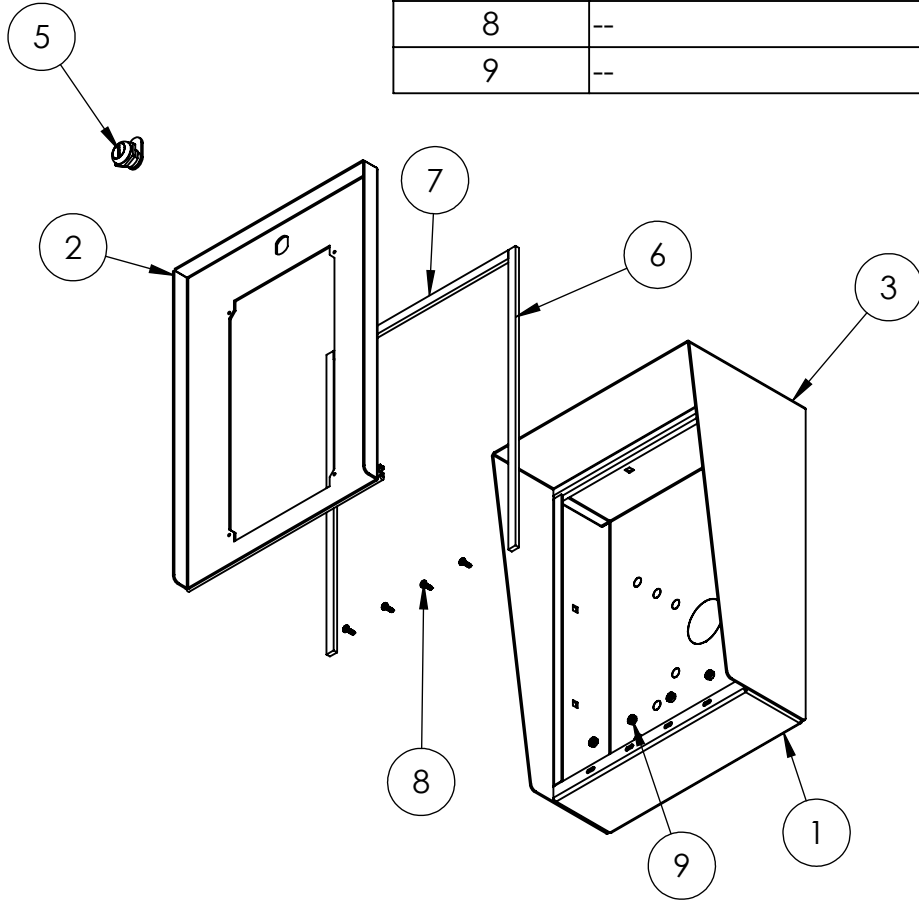

NOTES:

- SEE STANDARD PREPARATION AND COATING INSTRUCTIONS FOR COATING PROCEDURE AND COLOR.
- SEE STANDARD PACKAGING INSTRUCTIONS FOR PACKAGING PROCEDURE.

www.GooseneckStands.com (888) 378 - 1045 Sales@GooseneckStands.com	UNLESS OTHERWISE SPECIFIED:	NAME	DATE	TITLE:			
	DIMENSIONS ARE IN INCHES TOLERANCES: FRACTIONAL $\pm 1/32$ ANGULAR: $\pm 2^\circ$ TWO PLACE DECIMAL ± 0.010 THREE PLACE DECIMAL ± 0.005	DRAWN			ASSEMBLY	SIZE	PART NO.
INTERPRET GEOMETRIC TOLERANCING PER: ASME Y14.5 -2009	CHECKED			Wednesday, March 19, 2025 9:27:00 AM		A	1014HOU-AIPH-04-304
PROPRIETARY AND CONFIDENTIAL THE INFORMATION CONTAINED IN THIS DRAWING IS THE SOLE PROPERTY OF PEDESTALPRO LLC. ANY REPRODUCTION IN PART OR AS A WHOLE WITHOUT THE WRITTEN PERMISSION OF PEDESTALPRO LLC IS PROHIBITED.				WEIGHT: 13.874	NO SCALE	SHEET 2 OF 6	